



Flexsafe[®] Pro Mixer Pre-designed Solutions

The Fast, Flexible and Intelligent Single-Use Mixer
for All Mixing Steps in cGMP Bioprocessing

Simplifying Progress

SARTORIUS

Table of Contents

Please click on the headline to go to the selected topic

A Fast, Flexible and Intelligent Solution from 5 L up to 3,000 L.....	3
Assurance of Supply for All Fluid-contact Components.....	5
Validation and Quality Assurance.....	6
The Fast, Flexible and Intelligent Solution for All Mixing Steps in cGMP Bioprocessing.....	7
One Unique Mixing Solution for All Mixing Steps in cGMP Bioprocessing.....	8
Point-of-Use Leak Test for Flexsafe® Pro Mixer Bags.....	9

Media Formulation.....	10
Buffer Formulation.....	17
Downstream Intermediates.....	29
Drug Substance Purification.....	33
Drug Product Formulation.....	36

Hardware	
Palletank for Mixing.....	43
Pro Mixer Drive Unit.....	51
Accessories.....	52
Design, Application Development and Validation Services.....	58

Digital Selection Map

Please click on the box that matches your process needs

Media Formulation	pH sensor & Thermowell
	Thermowell
	No sensor
Media Formulation	pH sensor & Thermowell & Conductivity sensor
	Conductivity sensor & Thermowell
	pH sensor & Thermowell
	Thermowell
Downstream Intermediates	pH sensor & Thermowell
	Thermowell
	No sensor
Drug Substance Purification	pH sensor & Thermowell
	Thermowell
Downstream Intermediates	pH sensor & Thermowell
	No sensor & with sterile connections and disconnections
	No sensor & with aseptic connections and disconnections under ISO laminar air flow

A Fast, Flexible and Intelligent Solution From 5 L up to 3,000 L

Building on 20 years of experience in designing single-use fluid management solutions, we have established Pre-designed Solutions (PDS) for all process steps where either powerful or low shear mixing performances are required.

The Flexsafe® Pro Mixer is a unique, single-use mixer that can accommodate a wide range of mixing steps in both upstream and downstream processes.

Flexsafe® Pro Mixer consists of three main components:

- Flexsafe® Pro Mixer Bag
- Palletank® for Mixing or Bag Holder
- Pro Mixer drive or base unit

Flexsafe® Pro Mixer technology combines speed and efficiency to deliver high performance mixing during powder dissolution and a levitating impeller to preserve the drug during low shear blending applications:

- Its strong vertical vortex combined with a baffle effect and cubical tank design enables instant downward movement and the efficient dissolution of floating powders such as media.
- Its levitating impeller eliminates the shear effects that can impact product quality and prevents the generation of aggregates and particles that can reduce filtration performance.
- Its high torque facilitates the efficient mixing of high concentration or viscous powders such as buffers.
- Low shear mixing combined with a high torque allows the homogenization, viral inactivation and formulation of sensitive drug substances and products

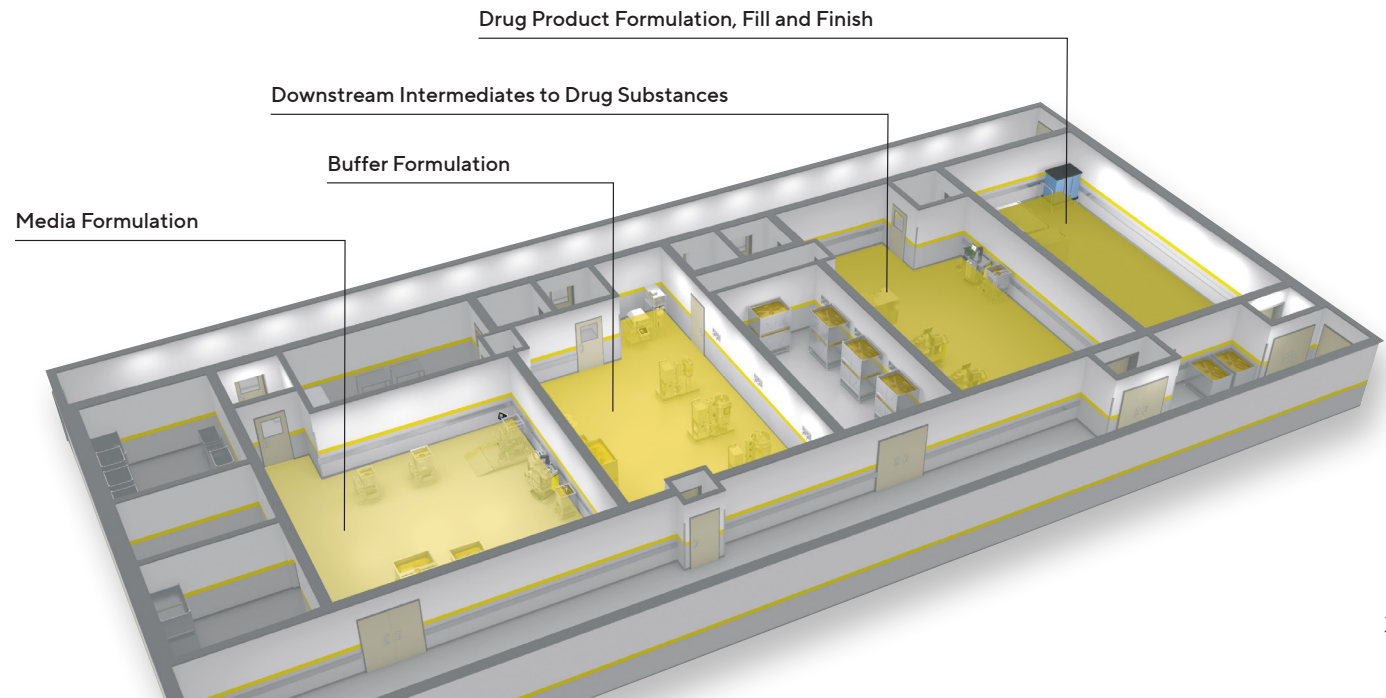

When you select a Flexsafe® Pro Mixer PDS, you get the simpler, safer, faster and cheaper supply chain solutions.

A Fast, Flexible and Intelligent Solution From 5 L up to 3,000 L

Media Formulation

Pre-designed Solutions
for media formulation



Drug Product Formulation

Pre-designed Solutions
for drug product
formulation



Buffer Formulation

Pre-designed Solutions
for buffer formulation

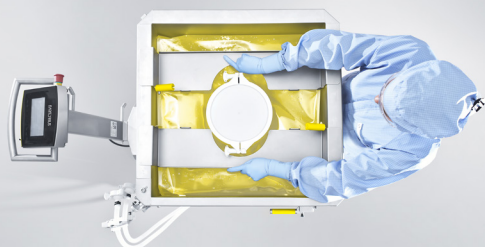

Downstream Intermediates

Pre-designed Solutions
for downstream
intermediates



Drug Substance Purification

Pre-designed Solutions
for drug substance
purification



Assurance of Supply for All Fluid-contact Components

Component Quality and Change Control

Fluid-contact components used for Flexsafe® Pro Mixer PDS are secured by long term contracts and quality agreements to offer an excellent assurance of supply. Our supply contracts and quality agreements ensure at least a 24-month change notification on fluid-contact components thus providing robust change control and business continuity.

Fluid-contact components are also available off-the-shelf to offer the excellent delivery ability.

Design Qualification

Component designs are selected to maximize tubing engagement tensile strength and tightness. Test samples are visually inspected for absence of defect and tested for leak, burst pressure, traction and compression.

Material Qualification

Flexsafe® Pro Mixer PDS components are evaluated for conformity against the EP and USP standards after reviewing technical documentation and certificates of quality available from our suppliers. Additional internal qualification tests are performed to establish extractable profiles, post gamma sterilization shelf life and consistent functional properties.

Criteria for Component Selection	Reference
Biological safety (USP Class VI)	USP<87> & USP<88>
TSE-BSE questionnaire	Compliance with EMA/410/01 and E.P 5.2.8
Endotoxin	USP<85> or EP 2.6.14
Bioburden	ISO 11737
Sub visible particles	USP<788> or EP 2.9.19
Others	Bisphenol A free, REACH compliance

Our core expertise in plastics and polymers enables the selection of highly clean and inert materials to minimize chemical interactions with biopharmaceutical fluids, and leacheable substances.

Flexsafe® Pro Mixer PDS

Components	Biocompatibility USP <87> or USP<88> Class VI	TSE-BSE MA/410/01 & REACH
Flexsafe® Pro Mixer bags	Yes	Yes
Impeller and cup	Yes	Yes
Top ports	Yes	Yes
TuFlux® tubes	Yes	Yes
Opta® sterile connectors	Yes	Yes
Fittings	Yes	Yes
Connectors	Yes	Yes
Sensors (conductivity, pH, Thermowell)	Yes	Yes
Drain valve	Yes	Yes

Using a Flexsafe® Pro Mixer Pre-designed Solution in all your process steps provide you with exceptional quality, change control, business continuity and delivery performances.

Validation and Quality Assurance

Flexsafe® Pro Mixer PDS are qualified against extensive biological, chemical, physical, extractable and functional testing.

Sartorius Stedim Biotech Quality Systems for single-use products follow applicable ISO 9001 standard. Design, manufacture, quality control and sterilization of PDS are conducted under conditions that mirror biopharmaceutical operations and meet cGMP like requirements to ensure they are supplied clean, pure, non-pyrogenic fluidpath and sterile.

PDS are validated and routinely controlled to provide consistent performance for:

Robustness

- Internal standardized methods for connection tests and functional qualification in real process conditions
- ASTM D882, ASTM D3787, F392 for tensile properties, resistance to puncture and flex durability

Gas Transmission (Film)

- ASTM F3985, ISO 15106-3, ASTM F2476: Oxygen, Water Vapor Transmission Rate and Carbon Dioxide.

Biocompatibility and Chemical Compatibility

- USP<87>: Biological reactivity tests, in Vitro
- USP<88>: Biological reactivity tests, in Vivo
- USP<661> and EP 3.1.5: Containers, physico-chemical tests – Plastics
- ASTM D543-06: resistance of plastic to chemical reagents

Purity, Extractable and Leachable

- Extractable data
- TSE/BSE: EP 5.2.8

Cleanliness, Particles and Sterilization

- USP<788> and EP 2.9.19: Particulate Matter in Injections Endotoxin
- Visible particles: Representative product has been analyzed for particles with sizes $\geq 100 \mu\text{m}$ according to internally developed and validated method. Results are monitored.
- USP<85> and E.P. 2.6.14: Bacterial endotoxins Sterility
- ISO 11737 Sterilization of medical
- ISO 11137 Sterilization by irradiation of Medical Devices: Sterilization of Medical Devices
- ISO 14644: Cleanroom environmental controls
- Gamma radiation dose mapping ISO 11137 Sterilization by irradiation of Medical Devices: Sterilization of Medical Devices

PDS for media, buffer, harvest & downstream intermediates and drug substance process steps are released on the basis of a weekly quality control for bioburden, sub-visible particulates and endotoxin performed on representative samples.

Media, Buffer, Downstream Intermediates & Drug substance

Weekly testing of bioburden, sub-visible particles and endotoxin on representative sample

Drug Product¹

Lot release testing of bioburden, sub-visible particles and endotoxin on actual product sample

¹ None of the PDS for Drug Product are yet released on the basis of a lot release testing

Certificate of Release

Statement	Monitoring*	100% Batch Testing	Particles Prevention Program
USP Class VI	Bioburden	Gamma radiation	Visible Particles monitoring
USP<87>: Biological reactivity tests, in Vitro	ISO 11737	Dose	
USP<88>: Biological reactivity tests, in Vivo	Endotoxin	Visual inspection	
	USP<85> and E.P. 2.6.14	Film, bag, seal and packaging	
Physico-chemical testing	Sub-visible Particulates	Technical Drawing conformity	
USP<661> and EP 3.1.5	USP<788> and EP 2.9.19	Batch record review	
TSE/BSE	Sterility		
EMA/410/01 rev 3 and EP 5.2.8	ISO 11137		

* performed weekly on representative samples

Assurance of Single-Use System Integrity

The assurance of container closure integrity of Flexsafe® Pro Mixer bags is proven along the entire product life cycle. Quality by design principles, process qualification, process control and quality control first ensure integrity of the film, the welds, and the bag chamber.

A Supplier Integrity Test (SIT) for the complete bag and line assemblies is available for Flexsafe® Pro Mixer Bags from 50 L up to 650 L, thus providing the best integrity assurance of the industry, mainly for critical applications.

For those critical process steps, a 100% point-of-use leak test avoids the risk of losing high value product and enhances patient and operator safety by ensuring that no damage occurred during shipping, storage, and handling of single-use Flexsafe® Pro Mixer bags at the user site.

Supplier Integrity Test

A supplier integrity test with Helium technology for 2 µm sensitivity is available for Flexsafe® Pro Mixer bags, from 50 to 650 L, and under a defined mixing bags design space.

Point of Use-Leak Test

A Point-of-Use Leak Test using pressure decay is available for end-users to test Flexsafe® Mixing bags from 50 L to 1,000 L in a fast and reliable way with the Sartocheck® 4 plus Bag tester.

These tests in conjunction with the control of our process ensure a highly stringent level of integrity and safety for patients and operators.

Process qualification at supplier

- Robustness validated in the extrusion design space
- Mechanical tests on film and weld
- Microbial immersion test
- Packaging validation
- Shipping validation

Process control & quality control at supplier

- Control of resin, extrusion, and welding process parameters
- Seal quality tests
- Visual inspections
- Microbial immersion test
- Supplier integrity testing for Flexsafe® Pro Mixer Bags up to 650 L

Process validation & process controls at end user

- Package integrity
- Visual inspection
- Media hold, media fill and stability test
- Microbial immersion test
- Operator training
- Point-of-use leak testing

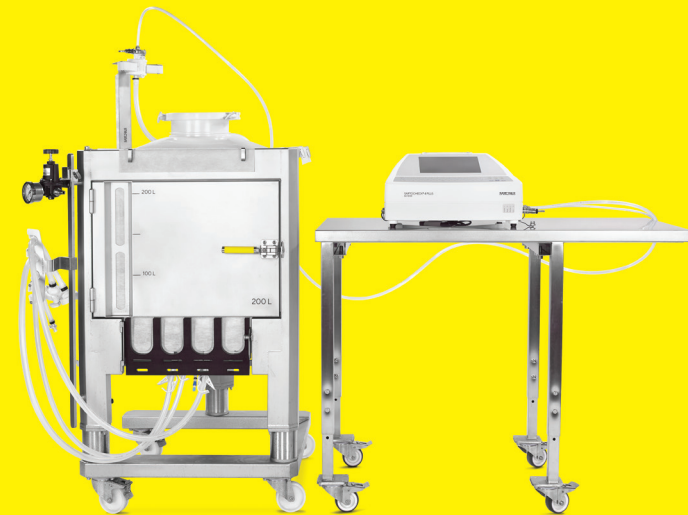

The Fast, Flexible and Intelligent Solution for All Mixing Steps in cGMP Bioprocessing

The Flexible and Ergonomic Design of the Flexsafe® Pro Mixer 5 – 3,000 L Offers Ease of Use:

The Flexsafe® Pro Mixer Bag (5 – 1,000 L) contains a central magnetic impeller assembly. Its unique sided K-weld design simplifies installation and facilitates the unfolding and folding of the bag during filling and draining operations. The 4" or 8" diameter top port allows easy and contained powder transfer into the mixing bag during buffer and media applications.

The Flexsafe® Pro Mixer Bag (1,500 to 3,000 L) contains an off-center magnetic impeller assembly and a 4" top port for powder transfer. Its bottom and top K-welds, combined with the Palletank lifting system, facilitates bag installation as well as filling and emptying operations.

The positioning of the tubing lines and sensors allow for easy installation and direct access during filling, sampling and draining.

The Flexsafe® Pro Mixer bag and Palletank are designed for easy product handling and quick-started processing just a few minutes after installation.

The drive unit touchscreen guides users from bag installation to the end of the mixing run with simple-to-follow instructions for each stage of the process.



Front door and cubical shape for an easy bag installation



Front access to sensors and tubing for easy manipulation



8 inches top opening for easy powder addition

Intelligent Mixing for Your cGMP Biomanufacturing

The Flexsafe® Pro Mixer provides the high levels of control that are essential for cGMP biomanufacturing:

- Inline control and monitoring of pH, conductivity and temperature are performed with a preassembled single-use pH probe, conductivity sensor and thermowell.
- Inline sensors meet PAT and cGMP requirements, eliminate the risk of contamination associated with reusable probes and reduce operator time.
- Palletank for Intelligent Mixers are available with weighing functions and heat exchange jackets for integrated volume and temperature control.
- The Pro Mixer drive unit features automated control, monitors the impeller speed, offers mixing recipes and includes password management.

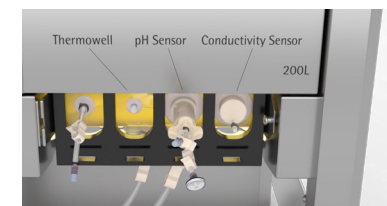

From left to right: sampling line, thermowell, pH sensor, conductivity sensor



Weight control (picture of one load cell)

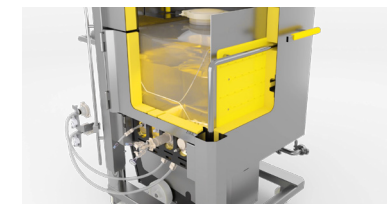

Heat exchange jacket and temperature control



Pro Mixer Drive unit touchscreen

One Unique Mixing Solution for All Mixing Steps in cGMP Bioprocessing

Top Lines

- pH adjustment lines with CPC Quick coupler or Opta® SFT female or when using drain valves on the bottom lines:
- top addition lines with CPC Quick coupler or Opta® SFT female
- and | or sampling line withclave needleless sampling port

Single-Use Sensors for in Line Measurement

- pH sensor with 2 calibration points
- Pre-calibrated conductivity sensor
- Thermowell for temperature measurement

Bottom Port

- Drain valve
- UPS 4 ports

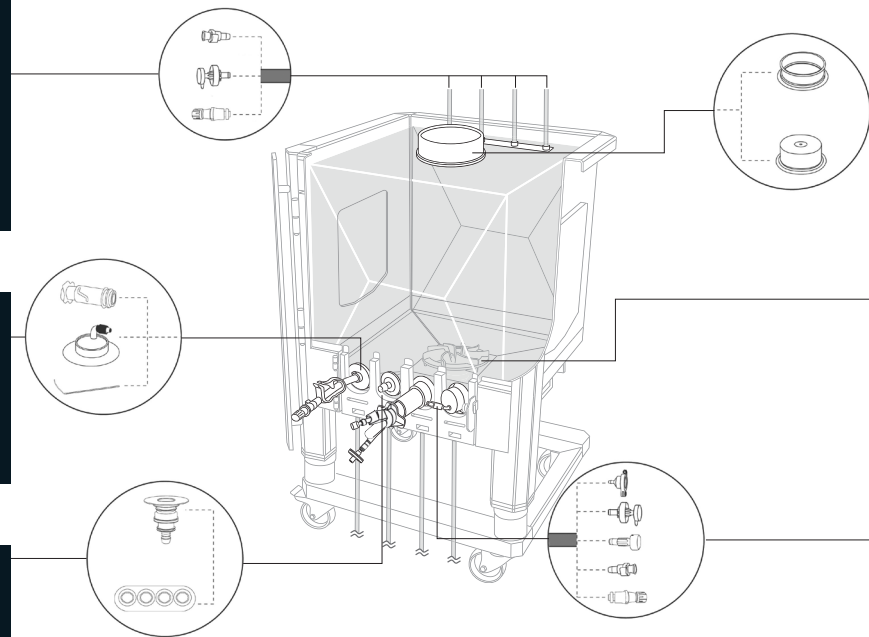

Large 8" diameter Top Port

- Opened Top Port for powder transfer
- Closed Top Port for sterile or low bioburden application

Mixing Technology

- Flexsafe® Pro Mixer is unique single-use mixer for both upstream and downstream processes

Bottom Lines

- Filling line with Tri-Clamp connector or Opta® SFT female
- Draining line with Tri-Clamp connector or Opta® SFT male
- Addition lines with CPC Quick coupler or Opta® SFT female
- Sampling line usingclave needleless sampling port

Inlet and Outlet Connectors

- Tri-Clamp 1½" sanitary flange are used for either sanitary connection or aseptic connection under ISO5 laminar air flow to stainless steel systems
- CPC quick couplers are used for either sanitary connection or aseptic connection under ISO5 laminar air flow to single-use systems
- Opta® SFT Female enables sterile connections to other single-use systems
- Clave needleless sampling port enables sterile sampling

Tubes

- TuFlux® Silicone tubing enables safe and fast pumping
- TuFlux® TPE tubing allows for sterile weld connection with BioWelder® TC and sterile seal disconnection with BioSealer®

Sensors

Single-use pH sensor:

- Electrochemical pH electrode with integrated Pt-1000
- Pre-installed and pre-sterilized single-use pH sensor
- Large measurement range pH2 - pH11, 4 - 50°C
- High accuracy after 2 points calibration: pH2 - pH11: ±0.08
- Retractable probe: 3 activations (insertion-removal-insertion) validated with maintained sterility

Single-use conductivity sensor:

- Pre-installed and pre-sterilized single-use conductivity sensor
- Pre-calibrated single-use conductivity sensor and ready to use
- Large measurement range 100 µS/cm up to 200 mS/cm
- Accuracy: <100 mS/cm: 3%
100 - 200 mS/cm: 5%

Thermowell:

- Compatible with reusable temperature probe of 3 mm diameter

Media Formulation

pH sensor & Thermowell

Thermowell

No sensor

Flexsafe® Pro Mixer technology combines speed and efficiency to deliver high performance mixing during powder dissolution such as media powder.

An optimized media formulation process involves filling the mixer with water for injection (WFI) up to 60% to 80% of the final volume. WFI can be heated up with the heat exchange jacket to accelerate the dissolution. The mixing drive unit is started and the media powder or a concentrated liquid media is added during mixing.

Once the dissolution is complete, WFI is added to adjust to the final volume. Volume adjustment can be automatically performed using weighing control.

Temperature and pH can be monitored and adjusted in-line. Process samples are taken off-line for other QC tests.

When the formulation is complete, the media is filtered for sterilization and mycoplasma removal and stored before further transfer to the bioreactor.

Flexsafe® Pro Mixer PDS for media are available in:

- Intelligent version using single-use and integrated sensors for in-line pH and temperature monitoring and adjustment required for your cGMP biomanufacture.
- Without sensor using either reusable sensors via the 4" or 8" top opening for in-line controls or sampling in single-use bags for off-line controls.

Filling and draining lines are available with TuFlux® Silicone tubing and Tri-Clamp 1½" sanitary flange. Samples can be taken via an additional TuFlux® Silicone line equipped with aclave needleless sampling port.

The following options are also available:

- Lines for other liquid additions with TuFlux® Silicone tubing and quick coupler connector.
- Drain valves to prevent powder accumulation in bottom tubing lines.

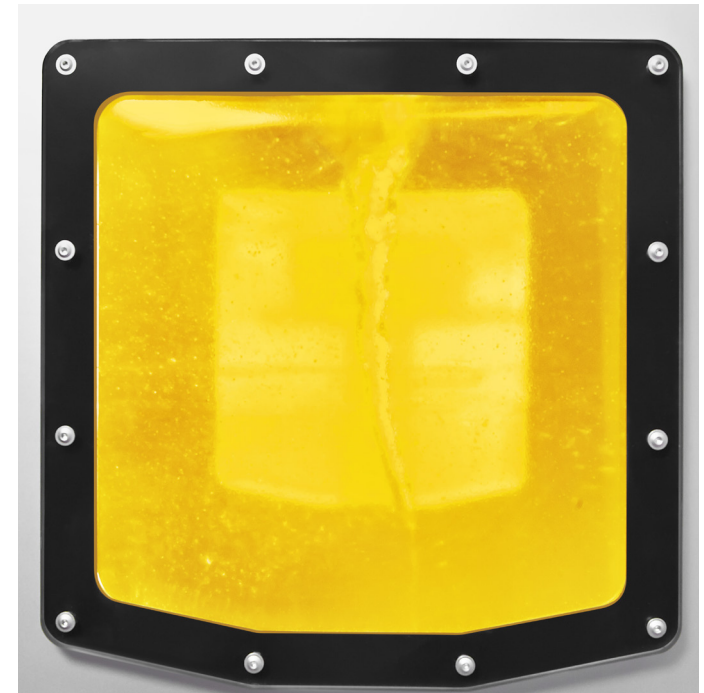

Media Formulation

pH sensor & Thermowell

Thermowell

No sensor

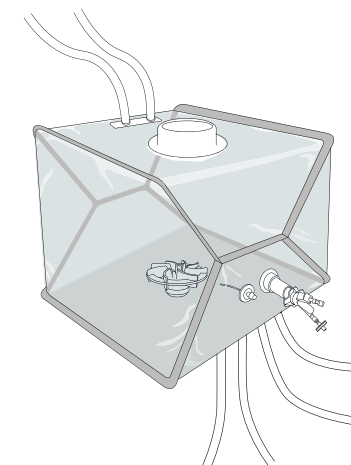

Example of a 200 L mixing bag equipped with pH sensor & Thermowell

Intelligent Flexsafe® Pro Mixer Bag with pH Sensor & Thermowell

Bag Volume	Part Number	Units per Box	Drain Valves	Top Port	Inlet	Outlet	Sampling	Addition 1	Addition 2	pH Adjustment
50 L	FMS500004	1	No	Opened 8" Top Port with gasket, cap & union	½" ID TuFlux® Silicone 1.5 m (60") + ½" Tri-Clamp	½" ID TuFlux® Silicone 1.5 m (60") + ½" Tri-Clamp	¼" ID TuFlux® Silicone 0.1 m (4") + Clave needleless sampling port	When drain valves: 1 top line: ¾" ID TuFlux® Silicone 0.15 m (6") + MPC Female + sealing cap	n/a	2 top lines: ¼" ID TuFlux® Silicone 0.1 m (4") + MPC female + sealing cap
	FMS500042	1	Yes							
100 L	FMS500005	1	No	Opened 8" Top Port with gasket, cap & union	1½" sanitary flange with gasket, cap & union	1½" sanitary flange with gasket, cap & union	¼" ID TuFlux® Silicone 0.1 m (4") + Clave needleless sampling port	When drain valves: 1 top line: ¾" ID TuFlux® Silicone 0.15 m (6") + MPC Female + sealing cap	n/a	2 top lines: ¼" ID TuFlux® Silicone 0.1 m (4") + MPC female + sealing cap
	FMS500043	1	Yes							
								When no drain valve: 1 bottom line: ¾" ID TuFlux® Silicone 1.5 m (60") + MPC Female + sealing cap		

Media Formulation

pH sensor & Thermowell

Thermowell

No sensor

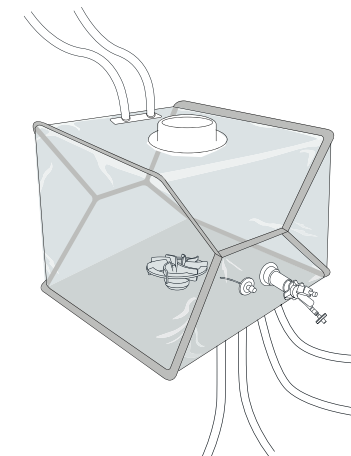

Example of a 200 L mixing bag equipped with pH sensor & Thermowell

Bag Volume	Part Number	Units per Box	Drain Valves	Top Port	Inlet	Outlet	Sampling	Addition 1	Addition 2	pH Adjustment
200 L	FMS500018	2	No	Opened 8" Top Port with gasket, cap & union	½" ID TuFlux® Silicone 1.5 m (60") + ½" Tri-Clamp	½" ID TuFlux® Silicone 1.5 m (60") + ½" Tri-Clamp	¾" ID TuFlux® Silicone 0.1 m (4") + Clave needleless sampling port	When drain valves:	When drain valves:	2 top lines: ¼" ID TuFlux® Silicone 0.1 m (4") + MPC female + sealing cap
	FMS500038	2	Yes					1 bottom line: ½" ID TuFlux® Silicone 1.5 m (60") + MPC Female + sealing cap	1 bottom line: ½" ID TuFlux® Silicone 1.5 m (60") + MPC Female + sealing cap	
400 L	FMS500019	2	No	Opened 8" Top Port with gasket, cap & union	1½" sanitary flange with gasket, cap & union	1½" sanitary flange with gasket, cap & union	¾" ID TuFlux® Silicone 0.1 m (4") + Clave needleless sampling port	When drain valves:	When drain valves:	2 top lines: ¼" ID TuFlux® Silicone 0.1 m (4") + MPC female + sealing cap
	FMS500039	2	Yes					1 bottom line: ½" ID TuFlux® Silicone 1.5 m (60") + MPC Female + sealing cap	1 bottom line: ½" ID TuFlux® Silicone 1.5 m (60") + MPC Female + sealing cap	
650 L	FMS500020	1	No	Opened 8" Top Port with gasket, cap & union	1½" sanitary flange with gasket, cap & union	1½" sanitary flange with gasket, cap & union	¾" ID TuFlux® Silicone 0.1 m (4") + Clave needleless sampling port	When no drain valve:	When no drain valve:	2 top lines: ¼" ID TuFlux® Silicone 0.1 m (4") + MPC female + sealing cap
	FMS500040	1	Yes					1 bottom line: ¾" ID TuFlux® Silicone 1.5 m (60") + MPC Female + sealing cap	1 bottom line: ¾" ID TuFlux® Silicone 1.5 m (60") + MPC Female + sealing cap	
1,000 L	FMS500021	1	No	Opened 8" Top Port with gasket, cap & union	1½" sanitary flange with gasket, cap & union	1½" sanitary flange with gasket, cap & union	¾" ID TuFlux® Silicone 0.1 m (4") + Clave needleless sampling port	When no drain valve:	When no drain valve:	2 top lines: ¼" ID TuFlux® Silicone 0.1 m (4") + MPC female + sealing cap
	FMS500041	1	Yes					1 bottom line: ¾" ID TuFlux® Silicone 1.5 m (60") + MPC Female + sealing cap	1 bottom line: ¾" ID TuFlux® Silicone 1.5 m (60") + MPC Female + sealing cap	
1,500 L	FMS500022	1	No	Opened 4" Top Port with gasket, cap & union	1" ID TuFlux® Silicone 3 m (119") + 1" Tri-Clamp	1" ID TuFlux® Silicone 3 m (119") + 1" Tri-Clamp	¾" ID TuFlux® Silicone 0.1 m (4") + Clave needleless sampling port	¾" ID TuFlux® Silicone 1.5 m (60") + ¾" Tri-Clamp	¾" ID TuFlux® Silicone 1.5 m (60") + ¾" Tri-Clamp	
2,000 L	FMS500023	1	No	Opened 4" Top Port with gasket, cap & union	1" ID TuFlux® Silicone 3 m (119") + 1" Tri-Clamp	1" ID TuFlux® Silicone 3 m (119") + 1" Tri-Clamp	¾" ID TuFlux® Silicone 0.1 m (4") + Clave needleless sampling port	¾" ID TuFlux® Silicone 1.5 m (60") + ¾" Tri-Clamp	¾" ID TuFlux® Silicone 1.5 m (60") + ¾" Tri-Clamp	
2,500 L	FMS500024	1	No	Opened 4" Top Port with gasket, cap & union	1½" sanitary flange with gasket, cap & union	1½" sanitary flange with gasket, cap & union	¾" ID TuFlux® Silicone 0.1 m (4") + Clave needleless sampling port	1½" sanitary flange with gasket, cap & union	1½" sanitary flange with gasket, cap & union	
3,000 L	FMS500025	1	No	Opened 4" Top Port with gasket, cap & union	1½" sanitary flange with gasket, cap & union	1½" sanitary flange with gasket, cap & union	¾" ID TuFlux® Silicone 0.1 m (4") + Clave needleless sampling port	1½" sanitary flange with gasket, cap & union	1½" sanitary flange with gasket, cap & union	

Media Formulation

pH sensor & Thermowell

Thermowell

No sensor

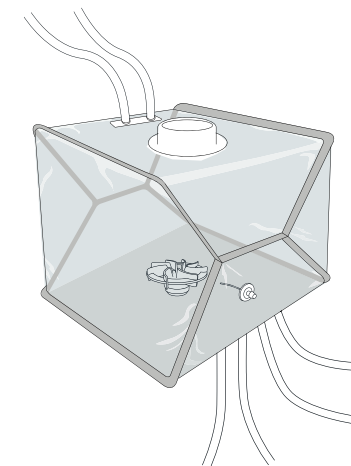

Example of a 200 L mixing bag equipped with Thermowell

Intelligent Flexsafe® Pro Mixer Bag with Thermowell

Bag Volume	Part Number	Units per Box	Drain Valves	Top Port	Inlet	Outlet	Sampling	Addition 1	Addition 2	pH Adjustment
50 L	FMS500044	1	Yes	Opened 8" Top Port with gasket, cap & union	½" ID TuFlux® Silicone 1.5 m (60") + ½" Tri-Clamp	½" ID TuFlux® Silicone 1.5 m (60") + ½" Tri-Clamp	¼" ID TuFlux® Silicone 0.1 m (4") + Clave needleless sampling port	When drain valves:	When drain valves:	2 top lines: ¼" ID TuFlux® Silicone 0.1 m (4") + MPC female + sealing cap
	FMS500045	1	No					Top line: ⅜" ID TuFlux® Silicone 0.15 m (6") + MPC Female + sealing cap	Top line: ⅜" ID TuFlux® Silicone 0.15 m (6") + MPC Female + sealing cap	
100 L	FMS500046	1	Yes	Opened 8" Top Port with gasket, cap & union	1½" sanitary flange with gasket, cap & union	1½" sanitary flange with gasket, cap & union	¼" ID TuFlux® Silicone 0.1 m (4") + Clave needleless sampling port	When drain valves:	When drain valves:	2 top lines: ¼" ID TuFlux® Silicone 0.1 m (4") + MPC female + sealing cap
	FMS500047	1	No					Bottom line: ⅜" ID TuFlux® Silicone 1.5 m (60") + MPC Female + sealing cap	Bottom line: ⅜" ID TuFlux® Silicone 1.5 m (60") + MPC Female + sealing cap	

Media Formulation

pH sensor & Thermowell

Thermowell

No sensor

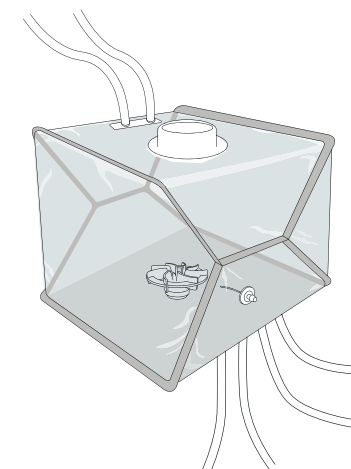

Example of a 200 L mixing bag equipped with Thermowell

Bag Volume	Part Number	Units per Box	Drain Valves	Top Port	Inlet	Outlet	Sampling	Addition 1	Addition 2	pH Adjustment
200 L	FMS500048	2	Yes	Opened 8" Top Port with gasket, cap & union	½" ID TuFlux® Silicone 1.5 m (60") + ½" Tri-Clamp	½" ID TuFlux® Silicone 1.5 m (60") + ½" Tri-Clamp	¼" ID TuFlux® Silicone 0.1 m (4") + Clave needleless sampling port	When drain valves: Bottom line: ½" ID TuFlux® Silicone 1.5 m (60") + MPC Female + sealing cap	When drain valves: Bottom line: ½" ID TuFlux® Silicone 1.5 m (60") + MPC Female + sealing cap	2 top lines: ¼" ID TuFlux® Silicone 0.1 m (4") + MPC female + sealing cap
	FMS500049	2	No							
400 L	FMS500050	2	Yes		1½" sanitary flange with gasket, cap & union	1½" sanitary flange with gasket, cap & union				
	FMS500051	2	No							
650 L	FMS500052	1	Yes					When no drain valve: Bottom line: ¾" ID TuFlux® Silicone 1.5 m (60") + MPC Female + sealing cap	When no drain valve: Bottom line: ¾" ID TuFlux® Silicone 1.5 m (60") + MPC Female + sealing cap	
	FMS500053	1	No							
1,000 L	FMS500054	1	Yes							
	FMS500055	1	No							
1,500 L	FMS500056	1	No	Opened 4" Top Port with gasket, cap & union	1" ID TuFlux® Silicone 3 m (119") + 1" Tri-Clamp	1" ID TuFlux® Silicone 3 m (119") + 1" Tri-Clamp	¼" ID TuFlux® Silicone 0.1 m (4") + Clave needleless sampling port	¾" ID TuFlux® Silicone 1.5 m (60") + ¾" Tri-Clamp	¾" ID TuFlux® Silicone 1.5 m (60") + ¾" Tri-Clamp	
2,000 L	FMS500057	1	No							
2,500 L	FMS500058	1	No							
3,000 L	FMS500059	1	No							

Media Formulation

pH sensor & Thermowell

Thermowell

No sensor

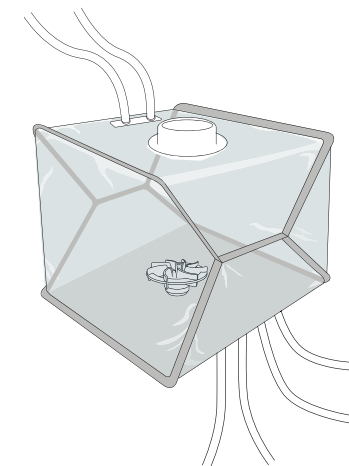

Example of a 200 L mixing bag without single-use sensor

Flexsafe® Pro Mixer Without Single-use Sensor

Bag Volume	Part Number	Units per Box	Drain Valves	Top Port	Inlet	Outlet	Sampling	Addition 1	Addition 2	pH Adjustment
5 L	FMS319774	1	No	Opened 4" Top Port	¼" ID TuFlux® Silicone 1.0 m (40")	¼" ID TuFlux® Silicone 1.0 m (40")	¼" ID TuFlux® Silicone 0.100 m + Clave needleless sampling port	n/a	n/a	n/a
10 L	FMS319775	1	No	Top Port with gasket, cap & union	+ 1.5" Tri-Clamp connector with gasket, cap & union	+ 1.5" Tri-Clamp connector with gasket, cap & union				
20 L	FMS319776	1	No	Opened 4" Top Port with gasket, cap & union	¾" ID TuFlux® Silicone 1.0 m (40") + 1.5" Tri-Clamp connector with gasket, cap & union	¾" ID TuFlux® Silicone 1.0 m (40") + 1.5" Tri-Clamp connector with gasket, cap & union	¼" ID TuFlux® Silicone 0.100 m + Clave needleless sampling port	n/a	n/a	n/a
50 L	FMS500060	1	Yes	Opened 8" Top Port	½" ID TuFlux® Silicone 1.5 m (60")	½" ID TuFlux® Silicone 1.5 m (60")	¼" ID TuFlux® Silicone 0.1 m (4")	n/a	n/a	n/a
	FMS500061	1	No	Top Port with gasket, cap & union	+ ½" Tri-Clamp	+ ½" Tri-Clamp	+ Clave needleless sampling port			
100 L	FMS500062	1	Yes		1½" sanitary flange with gasket, cap & union	1½" sanitary flange with gasket, cap & union				
	FMS500063	1	No							
200 L	FMS500064	2	Yes							
	FMS500065	2	No							

[Continue >](#)

Media Formulation

pH sensor & Thermowell

Thermowell

No sensor

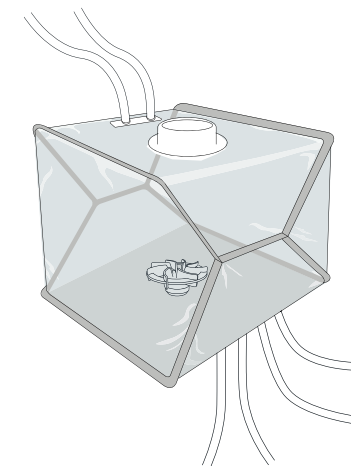

Example of a 200 L mixing bag without single-use sensor

Bag Volume	Part Number	Units per Box	Drain Valves	Top Port	Inlet	Outlet	Sampling	Addition 1	Addition 2	pH Adjustment
400 L	FMS500066	2	Yes	Opened 8" Top Port with gasket, cap & union	½" ID TuFlux®	½" ID TuFlux®	¼" ID TuFlux® Silicone 0.1 m (4") + Clave needleless sampling port	n/a	n/a	n/a
	FMS500067	2	No		Silicone 1.5 m (60") + ½" Tri-Clamp	Silicone 1.5 m (60") + ½" Tri-Clamp				
650 L	FMS500068	1	Yes	1½" sanitary flange with gasket, cap & union	1½" sanitary flange with gasket, cap & union	1½" sanitary flange with gasket, cap & union				
	FMS500069	1	No							
1,000 L	FMS500070	1	Yes	n/a	1" ID TuFlux® Silicone 3 m (119") + 1" Tri-Clamp	1" ID TuFlux® Silicone 3 m (119") + 1" Tri-Clamp	¼" ID TuFlux® Silicone 0.1 m (4") + Clave needleless sampling port	¾" ID TuFlux® Silicone 1.5 m (60") + ¾" Tri-Clamp	¾" ID TuFlux® Silicone 1.5 m (60") + ¾" Tri-Clamp	n/a
	FMS500071	1	No							
1,500 L	FMS500072	1	No	n/a	1" ID TuFlux® Silicone 3 m (119") + 1" Tri-Clamp	1" ID TuFlux® Silicone 3 m (119") + 1" Tri-Clamp	¼" ID TuFlux® Silicone 0.1 m (4") + Clave needleless sampling port	¾" ID TuFlux® Silicone 1.5 m (60") + ¾" Tri-Clamp	¾" ID TuFlux® Silicone 1.5 m (60") + ¾" Tri-Clamp	n/a
2,000 L	FMS500073	1	No		1½" sanitary flange with gasket, cap & union	1½" sanitary flange with gasket, cap & union		1½" sanitary flange with gasket, cap & union	1½" sanitary flange with gasket, cap & union	
2,500 L	FMS500074	1	No		1½" sanitary flange with gasket, cap & union	1½" sanitary flange with gasket, cap & union		1½" sanitary flange with gasket, cap & union	1½" sanitary flange with gasket, cap & union	
3,000 L	FMS500075	1	No		1½" sanitary flange with gasket, cap & union	1½" sanitary flange with gasket, cap & union		1½" sanitary flange with gasket, cap & union	1½" sanitary flange with gasket, cap & union	

Buffer Formulation

pH sensor, conductivity sensor & Thermowell

Conductivity sensor & Thermowell

pH sensor & Thermowell

Thermowell

No sensor

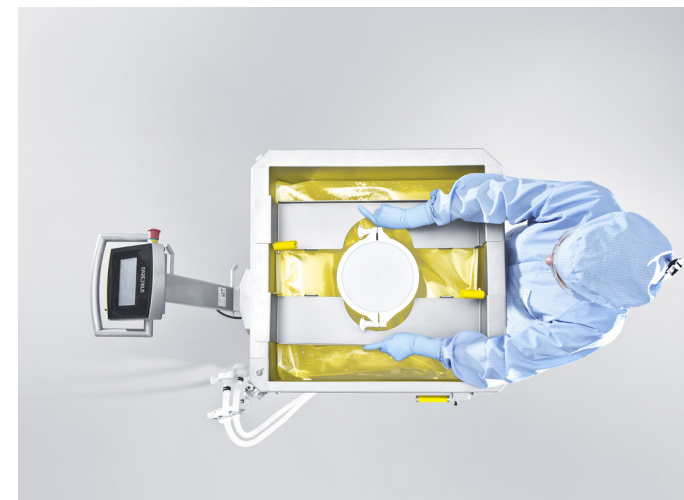

Flexsafe® Pro Mixer technology combines speed and efficiency to deliver high performance mixing during powder dissolution such as buffer powder.

An optimized buffer formulation process involves filling the mixer with water for injection (WFI) up to 60% to 80% of the final volume. WFI can be heated up with the heat exchange jacket to accelerate the dissolution. The mixing drive unit is started and the buffer powder or a concentrated liquid buffer is added during mixing.

Once the dissolution is complete, WFI is added to adjust to the final volume. Volume adjustment can be automatically performed using weighing control.

Temperature, conductivity, and pH can be monitored and adjusted in-line. Process samples are taken off-line for other QC tests.

When the formulation is complete, the buffer is sterile filtered and stored before further use for drug substance purification or final drug product formulation.

Flexsafe® Pro Mixer PDS for buffer are available in:

- Intelligent version using single-use and integrated sensors for in-line pH, conductivity and temperature monitoring and adjustment required for your cGMP biomanufacture.
- Without sensor using either reusable sensors via the 8" top opening for in-line controls or sampling in single-use bags for off-line controls.

Filling and draining lines are available with TuFlux® Silicone tubing and Tri-Clamp 1½" sanitary flange. Samples can be taken via TuFlux® Silicone line equipped with aclave needleless sampling port.

The following options are also available:

- Lines for liquid additions with TuFlux® Silicone tubing and quick coupler connector.
- Drain valves to prevent powder accumulation in bottom mounted tubing.

Buffer Formulation

pH sensor, conductivity sensor & Thermowell

Conductivity sensor & Thermowell

pH sensor & Thermowell

Thermowell

No sensor

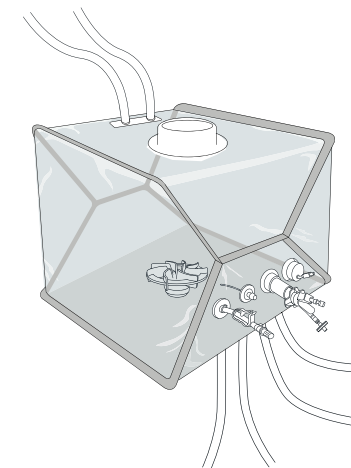

Example of a 200 L mixing bag equipped with pH sensor, conductivity sensor & Thermowell

Intelligent Flexsafe® Pro Mixer Bag with pH Sensor, Conductivity sensor & Thermowell

Bag Volume	Part Number	Units per Box	Drain Valves	Top Port	Inlet	Outlet	Sampling	Addition 1	Addition 2	pH Adjustment
50 L	FMS500014	1	No	Opened 8"	½" ID TuFlux®	½" ID TuFlux®	¼" ID TuFlux®	When drain valves: n/a	When drain valves: n/a	2 top lines: ¾" ID TuFlux® Silicone 0.1 m (4") + MPC female + sealing cap
	FMS500015	1	Yes	Top Port with gasket, cap & union	Silicone 1.5 m (60") + ½" Tri-Clamp	Silicone 1.5 m (60") + ½" Tri-Clamp	Silicone 0.1 m (4") + Clave needleless sampling port			
100 L	FMS500017	1	No		1½" sanitary flange with gasket, cap & union	1½" sanitary flange with gasket, cap & union		When no drain valve: 1 top line: ¾" ID TuFlux® Silicone 0.15 m (6") + MPC Female + sealing cap	When no drain valve: 1 top line: ¾" ID TuFlux® Silicone 0.15 m (6") + MPC Female + sealing cap	
	FMS500016	1	Yes							

[Continue >](#)

**Buffer
Formulation****pH sensor, conductivity sensor & Thermowell**

Conductivity sensor & Thermowell

pH sensor & Thermowell

Thermowell

No sensor

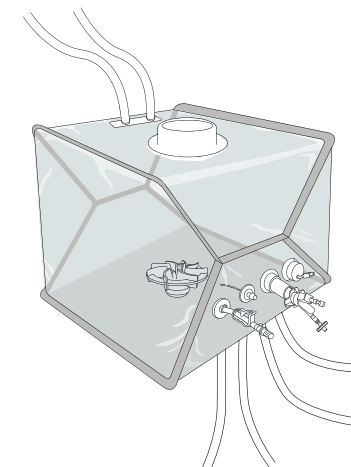

Example of a 200 L mixing bag equipped with pH sensor, conductivity sensor & Thermowell

Intelligent Flexsafe® Pro Mixer Bag with pH Sensor, Conductivity sensor & Thermowell

Bag Volume	Part Number	Units per Box	Drain Valves	Top Port	Inlet	Outlet	Sampling	Addition 1	Addition 2	pH Adjustment
200 L	FMS500006	2	No	Opened 8" Top Port with gasket, cap & union	½" ID TuFlux® Silicone 1.5 m (60") + ½" Tri-Clamp	½" ID TuFlux® Silicone 1.5 m (60") + ½" Tri-Clamp	¼" ID TuFlux® Silicone 0.1 m (4") + Clave needleless sampling port	When drain valves: 1 bottom line: ½" ID TuFlux® Silicone 1.5 m (60") + MPC Female + sealing cap	When drain valves: 1 bottom line: ½" ID TuFlux® Silicone 1.5 m (60") + MPC Female + sealing cap	2 top lines: ¼" ID TuFlux® Silicone 0.1 m (4") + MPC female + sealing cap
	FMS500007	2	Yes							
400 L	FMS500008	2	No	Opened 4" Top Port with gasket, cap & union	1½" sanitary flange with gasket, cap & union	1½" sanitary flange with gasket, cap & union		When no drain valve: 1 bottom line: ¾" ID TuFlux® Silicone 1.5 m (60") + MPC Female + sealing cap	When no drain valve: 1 bottom line: ¾" ID TuFlux® Silicone 1.5 m (60") + MPC Female + sealing cap	
	FMS500009	2	Yes							
650 L	FMS500010	1	No	Opened 4" Top Port with gasket, cap & union	1" ID TuFlux® Silicone 3 m (119") + 1" Tri-Clamp	1" ID TuFlux® Silicone 3 m (119") + 1" Tri-Clamp	¼" ID TuFlux® Silicone 0.1 m (4") + Clave needleless sampling port			
	FMS500011	1	Yes							
1,000 L	FMS500012	1	No	Opened 4" Top Port with gasket, cap & union	1½" sanitary flange with gasket, cap & union	1½" sanitary flange with gasket, cap & union				
	FMS500013	1	Yes							
1,500 L	FMS500000	1	No	Opened 4" Top Port with gasket, cap & union	1" ID TuFlux® Silicone 3 m (119") + 1" Tri-Clamp	1" ID TuFlux® Silicone 3 m (119") + 1" Tri-Clamp	¼" ID TuFlux® Silicone 0.1 m (4") + Clave needleless sampling port	¾" ID TuFlux® Silicone 1.5 m (60") + ¾" Tri-Clamp	¾" ID TuFlux® Silicone 1.5 m (60") + ¾" Tri-Clamp	
2,000 L	FMS500001	1	No	Opened 4" Top Port with gasket, cap & union	1½" sanitary flange with gasket, cap & union	1½" sanitary flange with gasket, cap & union		1½" sanitary flange with gasket, cap & union	1½" sanitary flange with gasket, cap & union	
2,500 L	FMS500002	1	No	Opened 4" Top Port with gasket, cap & union	1½" sanitary flange with gasket, cap & union	1½" sanitary flange with gasket, cap & union		1½" sanitary flange with gasket, cap & union	1½" sanitary flange with gasket, cap & union	
3,000 L	FMS500003	1	No	Opened 4" Top Port with gasket, cap & union	1½" sanitary flange with gasket, cap & union	1½" sanitary flange with gasket, cap & union		1½" sanitary flange with gasket, cap & union	1½" sanitary flange with gasket, cap & union	

Buffer Formulation

pH sensor, conductivity sensor & Thermowell

Conductivity sensor & Thermowell

pH sensor & Thermowell

Thermowell

No sensor

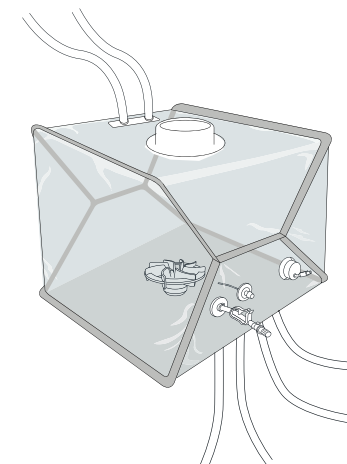

Example of a 200 L mixing bag equipped with conductivity sensor & Thermowell

Intelligent Flexsafe® Pro Mixer Bag with Conductivity sensor & Thermowell

Bag Volume	Part Number	Units per Box	Drain Valves	Top Port	Inlet	Outlet	Sampling	Addition 1	Addition 2	pH Adjustment
50 L	FMS500112	1	No	Opened 8" Top Port with gasket, cap & union	½" ID TuFlux®	½" ID TuFlux®	¼" ID TuFlux®	When drain valves: 1 top line: ¾ ¾" ID TuFlux® Silicone 0.15 m (6") + MPC Female + sealing cap	n/a	n/a
	FMS500138	1	Yes		½" ID TuFlux® Silicone 1.5 m (60") + ½" Tri-Clamp	½" ID TuFlux® Silicone 1.5 m (60") + ½" Tri-Clamp	¼" ID TuFlux® Silicone 0.1 m (4") + Clave needleless sampling port			
100 L	FMS500113	1	No	Opened 8" Top Port with gasket, cap & union	1½" sanitary flange with gasket, cap & union	1½" sanitary flange with gasket, cap & union	¼" ID TuFlux® Silicone 0.15 m (6") + MPC Female + sealing cap	When no drain valve: 1 bottom line: ¾" ID TuFlux® Silicone 1.5 m (60") + MPC Female + sealing cap	n/a	n/a
	FMS500139	1	Yes		1½" sanitary flange with gasket, cap & union	1½" sanitary flange with gasket, cap & union				

[Continue >](#)

Buffer Formulation

pH sensor, conductivity sensor & Thermowell

Conductivity sensor & Thermowell

pH sensor & Thermowell

Thermowell

No sensor

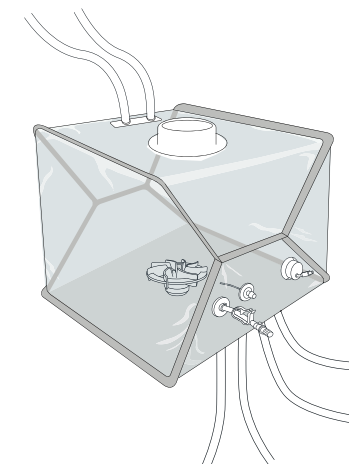

Example of a 200 L mixing bag equipped with conductivity sensor & Thermowell

Intelligent Flexsafe® Pro Mixer Bag with Conductivity sensor & Thermowell

Bag Volume	Part Number	Units per Box	Drain Valves	Top Port	Inlet	Outlet	Sampling	Addition 1	Addition 2	pH Adjustment
200 L	FMS500026	2	No	Opened 8" Top Port with gasket, cap & union	½" ID TuFlux®	½" ID TuFlux®	¼" ID TuFlux® Silicone 0.1 m (4") + Clave needleless sampling port	When drain valves: 1 bottom line: ½" ID TuFlux® Silicone 1.5 m (60") + MPC Female + sealing cap	When drain valves: 1 bottom line: ½" ID TuFlux® Silicone 1.5 m (60") + MPC Female + sealing cap	n/a
	FMS500027	2	Yes		+ ½" Tri-Clamp	+ ½" Tri-Clamp				
400 L	FMS500028	2	No		1½" sanitary flange with gasket, cap & union	1½" sanitary flange with gasket, cap & union				
	FMS500029	2	Yes							
650 L	FMS500030	1	No					When no drain valve: 1 bottom line: a" ID TuFlux® Silicone 1.5 m (60") + MPC Female + sealing cap	When no drain valve: 1 bottom line: a" ID TuFlux® Silicone 1.5 m (60") + MPC Female + sealing cap	
	FMS500031	1	Yes							
1,000 L	FMS500032	1	No							
	FMS500033	1	Yes							
1,500 L	FMS500034	1	No	Opened 4" Top Port with gasket, cap & union	1" ID TuFlux® Silicone 3 m (119") +1" Tri-Clamp	1" ID TuFlux® Silicone 3 m (119") +1" Tri-Clamp	¼" ID TuFlux® Silicone 0.1 m (4") + Clave needleless sampling port	¾" ID TuFlux® Silicone 1,5 m (60") + ¾" Tri-Clamp	¾" ID TuFlux® Silicone 1,5 m (60") + ¾" Tri-Clamp	
2,000 L	FMS500035	1	No							
2,500 L	FMS500036	1	No		1½" sanitary flange with gasket, cap & union	1½" sanitary flange with gasket, cap & union		1½" sanitary flange with gasket, cap & union	1½" sanitary flange with gasket, cap & union	
3,000 L	FMS500037	1	No							

Buffer Formulation

pH sensor, conductivity sensor & Thermowell

Conductivity sensor & Thermowell

pH sensor & Thermowell

Thermowell

No sensor

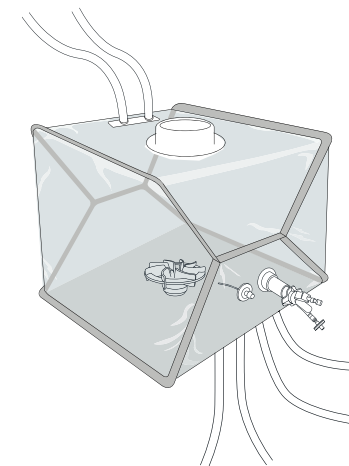

Example of a 200 L mixing bag equipped with pH sensor & Thermowell

Intelligent Flexsafe® Pro Mixer with pH sensor & Thermowell

Bag Volume	Part Number	Units per Box	Drain Valves	Top Port	Inlet	Outlet	Sampling	Addition 1	Addition 2	pH Adjustment
50 L	FMS500004	1	No	Opened 8" Top Port with gasket, cap & union	½" ID TuFlux®	½" ID TuFlux®	¼" ID TuFlux®	When drain valves: 1 top line: ¾" ID TuFlux® Silicone 0.15 m (6") + MPC Female + sealing cap	n/a	2 top lines: ¾" ID TuFlux® Silicone 0.1 m (4") + MPC female + sealing cap
	FMS500042	1	Yes		½" ID TuFlux® Silicone 1.5 m (60") + ½" Tri-Clamp	½" ID TuFlux® Silicone 1.5 m (60")	¼" ID TuFlux® Silicone 0.1 m (4")			
100 L	FMS500005	1	No	Opened 8" Top Port with gasket, cap & union	1½" sanitary flange with gasket, cap & union	+ ½" Tri-Clamp	+ Clave needleless sampling port	When no drain valve: 1 bottom line: ¾" ID TuFlux® Silicone 1.5 m (60") + MPC Female + sealing cap		
	FMS500043	1	Yes		1½" sanitary flange with gasket, cap & union	1½" sanitary flange with gasket, cap & union	¼" ID TuFlux® Silicone 0.1 m (4")			

[Continue >](#)

Buffer Formulation

pH sensor, conductivity sensor & Thermowell

Conductivity sensor & Thermowell

pH sensor & Thermowell

Thermowell

No sensor

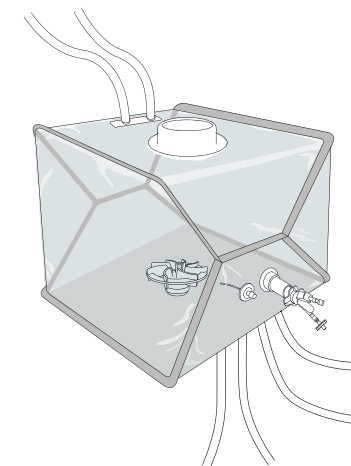

Example of a 200 L mixing bag equipped with pH sensor & Thermowell

Intelligent Flexsafe® Pro Mixer with pH sensor & Thermowell

Bag Volume	Part Number	Units per Box	Drain Valves	Top Port	Inlet	Outlet	Sampling	Addition 1	Addition 2	pH Adjustment
200 L	FMS500018	2	No	Opened 8" Top Port with gasket, cap & union	½" ID TuFlux® Silicone 1.5 m (60") + ½" Tri-Clamp	½" ID TuFlux® Silicone 1.5 m (60") + ½" Tri-Clamp	¼" ID TuFlux® Silicone 0.1 m (4") + Clave needleless sampling port	When drain valves:	When drain valves:	2 top lines: ¼" ID TuFlux® Silicone 0.1 m (4") + MPC female + sealing cap
	FMS500038	2	Yes					1 bottom line: ½" ID TuFlux® Silicone 1.5 m (60") + MPC Female + sealing cap	1 bottom line: ½" ID TuFlux® Silicone 1.5 m (60") + MPC Female + sealing cap	
400 L	FMS500019	2	No	1½" sanitary flange with gasket, cap & union	1½" sanitary flange with gasket, cap & union	1½" sanitary flange with gasket, cap & union		Silicone 1.5 m (60") + MPC Female + sealing cap	Silicone 1.5 m (60") + MPC Female + sealing cap	
	FMS500039	2	Yes							
650 L	FMS500020	1	No					When no drain valve: 1 bottom line: ⅜" ID TuFlux® Silicone 1.5 m (60") + MPC Female + sealing cap	When no drain valve:	
	FMS500040	1	Yes						1 bottom line: ⅜" ID TuFlux® Silicone 1.5 m (60") + MPC Female + sealing cap	
1,000 L	FMS500021	1	No					Silicone 1.5 m (60") + MPC Female + sealing cap	Silicone 1.5 m (60") + MPC Female + sealing cap	
	FMS500041	1	Yes							

[Continue >](#)

Buffer Formulation

pH sensor, conductivity sensor & Thermowell

Conductivity sensor & Thermowell

pH sensor & Thermowell

Thermowell

No sensor

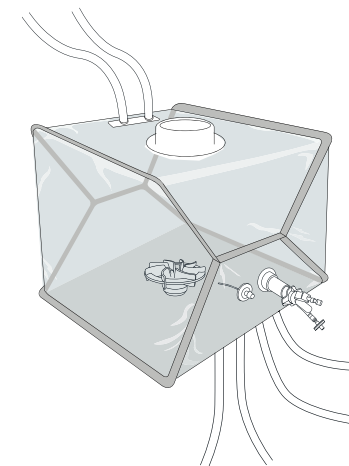

Example of a 200 L mixing bag equipped with pH sensor & Thermowell

Intelligent Flexsafe® Pro Mixer with pH sensor & Thermowell

Bag Volume	Part Number	Units per Box	Drain Valves	Top Port	Inlet	Outlet	Sampling	Addition 1	Addition 2	pH Adjustment
1,500 L	FMS500022	1	No	Opened 4" Top Port with gasket, cap & union	1" ID TuFlux® Silicone 3 m (119") +1" Tri-Clamp	1" ID TuFlux® Silicone 3 m (119")	¼" ID TuFlux® Silicone 0.1 m (4") + Clave needleless sampling port	¾" ID TuFlux® Silicone 1.5 m (60") + ¾" Tri-Clamp	¾" ID TuFlux® Silicone 1.5 m (60")	
2,000 L	FMS500023	1	No		1½" sanitary flange with gasket, cap & union	+1" Tri-Clamp	1½" sanitary flange with gasket, cap & union	1½" sanitary flange with gasket, cap & union	1½" sanitary flange with gasket, cap & union	
2,500 L	FMS500024	1	No							
3,000 L	FMS500025	1	No							

Buffer Formulation

pH sensor, conductivity sensor & Thermowell

Conductivity sensor & Thermowell

pH sensor & Thermowell

Thermowell

No sensor

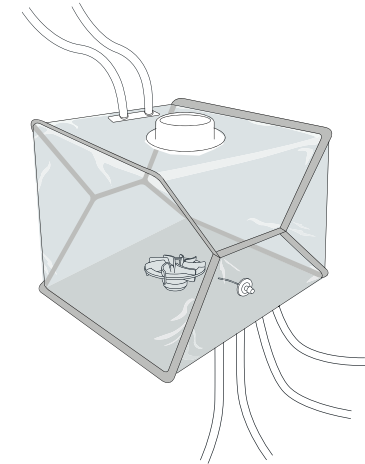

Example of a 200 L mixing bag equipped with Thermowell

Intelligent Flexsafe® Pro Mixer with Thermowell

Bag Volume	Part Number	Units per Box	Drain Valves	Top Port	Inlet	Outlet	Sampling	Addition 1	Addition 2	pH Adjustment
50 L	FMS500044	1	Yes	Opened 8"	½" ID TuFlux®	½" ID TuFlux®	¼" ID TuFlux®	When drain valves:	When drain valves:	2 top lines: ¼" ID TuFlux® Silicone 0.1 m (4") + MPC female + sealing cap
	FMS500045	1	No	Top Port with gasket, cap & union	Silicone 1.5 m (60") + ½" Tri-Clamp	Silicone 1.5 m (60") + ½" Tri-Clamp	Silicone 0.1 m (4") + Clave needleless sampling port	Top line: ¾" ID TuFlux® Silicone 0.15 m (6") + MPC Female + sealing cap	Top line: ¾" ID TuFlux® Silicone 0.15 m (6") + MPC Female + sealing cap	
100 L	FMS500046	1	Yes		1½" sanitary flange with gasket, cap & union	1½" sanitary flange with gasket, cap & union		When no drain valve:	When no drain valve:	
	FMS500047	1	No					Bottom line: ¾" ID TuFlux® Silicone 1.5 m (60") + MPC Female + sealing cap	Bottom line: ¾" ID TuFlux® Silicone 1.5 m (60") + MPC Female + sealing cap	

[Continue >](#)

Buffer Formulation

pH sensor, conductivity sensor & Thermowell

Conductivity sensor & Thermowell

pH sensor & Thermowell

Thermowell

No sensor

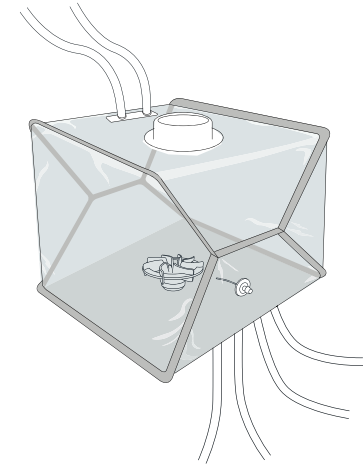

Example of a 200 L mixing bag equipped with Thermowell

Intelligent Flexsafe® Pro Mixer with Thermowell

Bag Volume	Part Number	Units per Box	Drain Valves	Top Port	Inlet	Outlet	Sampling	Addition 1	Addition 2	pH Adjustment
200 L	FMS500048	2	Yes	Opened 8" Top Port	½" ID TuFlux® Silicone 1.5 m (60") + ½" Tri-Clamp	½" ID TuFlux® Silicone 1.5 m (60") + ½" Tri-Clamp	¾" ID TuFlux® Silicone 0.1 m (4") + Clave needleless sampling port	When drain valves: Bottom line: ½" ID TuFlux® + MPC Female + sealing cap	When drain valves: Bottom line: ½" ID TuFlux® Silicone 1.5 m (60") + MPC Female + sealing cap	2 top lines: ¾" ID TuFlux® Silicone 0.1 m (4") + MPC female + sealing cap
	FMS500049	2	No							
400 L	FMS500050	2	Yes	Opened 8" Top Port with gasket, cap & union	1½" sanitary flange with gasket, cap & union	1½" sanitary flange with gasket, cap & union				
	FMS500051	2	No							
650 L	FMS500052	1	Yes							
	FMS500053	1	No					When no drain valve: Bottom line: ¾" ID TuFlux® Silicone 1.5 m (60") + MPC Female + sealing cap	When no drain valve: Bottom line: ¾" ID TuFlux® Silicone 1.5 m (60") + MPC Female + sealing cap	
1,000 L	FMS500054	1	Yes							
	FMS500055	1	No							
1,500 L	FMS500056	1	No	Opened 4" Top Port with gasket, cap & union	1" ID TuFlux® Silicone 3 m (119") + 1" Tri-Clamp	1" ID TuFlux® Silicone 3 m (119") + 1" Tri-Clamp	¾" ID TuFlux® Silicone 0.1 m (4") + Clave needleless sampling port	¾" ID TuFlux® Silicone 1.5 m (60") + ¾" Tri-Clamp	¾" ID TuFlux® Silicone 1.5 m (60") + ¾" Tri-Clamp	
2,000 L	FMS500057	1	No							
2,500 L	FMS500058	1	No							
3,000 L	FMS500059	1	No							

Buffer Formulation

pH sensor, conductivity sensor & Thermowell

Conductivity sensor & Thermowell

pH sensor & Thermowell

Thermowell

No sensor

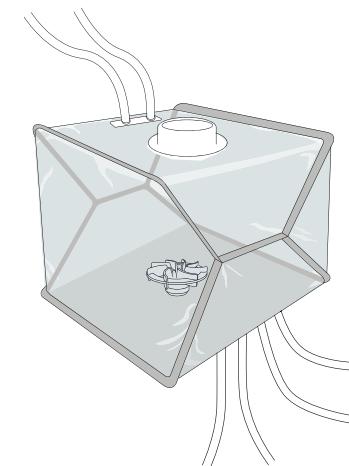

Example of a 200 L mixing bag
without single-use sensor

Flexsafe® Pro Mixer Without Single-use Sensor

Bag Volume	Part Number	Units per Box	Drain Valves	Top Port	Inlet	Outlet	Sampling	Addition 1	Addition 2	pH Adjustment
5 L	FMS319774	1	No	Opened 4"	¼" ID TuFlux®	¼" ID TuFlux®	¼" ID TuFlux®	n/a	n/a	n/a
10 L	FMS319775	1	No	Top Port with gasket, cap & union	Silicone 1,0 m (40") + 1.5" Tri-Clamp connector with gasket, cap & union	Silicone 1,0 m (40") + 1.5" Tri-Clamp connector with gasket, cap & union	Silicone 0.100 m + Clave needleless sampling port			
20 L	FMS319776	1	No	Opened 4" Top Port with gasket, cap & union	⅜" ID TuFlux® Silicone 1,0 m (40") + 1.5" Tri-Clamp connector with gasket, cap & union	⅜" ID TuFlux® Silicone 1,0 m (40") + 1.5" Tri-Clamp connector with gasket, cap & union	¼" ID TuFlux® Silicone 0.100 m + Clave needleless sampling port	n/a	n/a	n/a
50 L	FMS500060	1	Yes	Opened 8"	½" ID TuFlux®	½" ID TuFlux®	¼" ID TuFlux®	n/a	n/a	n/a
	FMS500061	1	No	Top Port with gasket, cap & union	Silicone 1.5 m (60") + ½" Tri-Clamp	Silicone 1.5 m (60") + ½" Tri-Clamp	Silicone 0.1 m (4") + Clave needleless sampling port			
100 L	FMS500062	1	Yes		1½" sanitary flange with gasket, cap & union	1½" sanitary flange with gasket, cap & union				
	FMS500063	1	No							
200 L	FMS500064	2	Yes							
	FMS500065	2	No							

[Continue >](#)

Buffer Formulation

pH sensor, conductivity sensor & Thermowell

Conductivity sensor & Thermowell

pH sensor & Thermowell

Thermowell

No sensor

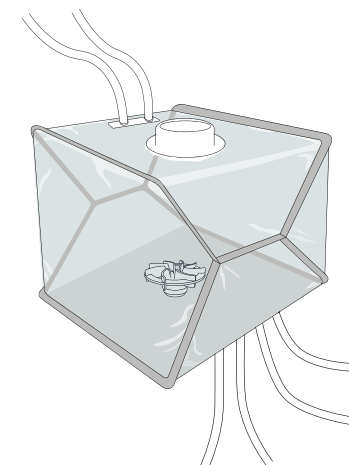

Example of a 200 L mixing bag
without single-use sensor

Bag Volume	Part Number	Units per Box	Drain Valves	Top Port	Inlet	Outlet	Sampling	Addition 1	Addition 2	pH Adjustment
400 L	FMS500066	2	Yes	Opened 8"	½" ID TuFlux®	½" ID TuFlux®	¼" ID TuFlux®	n/a	n/a	n/a
	FMS500067	2	No	Top Port with gasket, cap & union	Silicone 1.5 m (60") + ½" Tri-Clamp	Silicone 1.5 m (60") + ½" Tri-Clamp	Silicone 0.1 m (4") + Clave needleless sampling port			
650 L	FMS500068	1	Yes		1½" sanitary flange with gasket, cap & union	1½" sanitary flange with gasket, cap & union				
	FMS500069	1	No							
1,000 L	FMS500070	1	Yes							
	FMS500071	1	No							
1,500 L	FMS500072	1	No	n/a	1" ID TuFlux® Silicone 3 m (119")	1" ID TuFlux® Silicone 3 m (119")	¼" ID TuFlux® Silicone 0.1 m (4") + Clave needleless sampling port	¾" ID TuFlux® Silicone 1,5 m (60") + ¾" Tri-Clamp	¾" ID TuFlux® Silicone 1.5 m (60") + ¾" Tri-Clamp	n/a
2,000 L	FMS500073	1	No		+ 1" Tri-Clamp	+ 1" Tri-Clamp				
2,500 L	FMS500074	1	No		1½" sanitary flange with gasket, cap & union	1½" sanitary flange with gasket, cap & union		1½" sanitary flange with gasket, cap & union	1½" sanitary flange with gasket, cap & union	
3,000 L	FMS500075	1	No							

Downstream Intermediates

pH sensor & Thermowell

Thermowell

No sensor

Flexsafe® Pro Mixer technology allows low shear mixing to preserve the drug during viral inactivation. PDS are designed with single-use sensors for reliable use along the process steps.

Low pH viral inactivation of downstream process intermediates consists of 3 steps:

The pH of the downstream intermediate is first reduced and maintained at low pH for a validated period of time, usually at pH 3–4 for an hour, until the virus is totally inactivated. The low pH inactivation is followed by a neutralisation step where the pH is increased, usually up to pH 7–8 and a final filtration.

All three steps require mixing for inactivation, neutralization and homogenization.

To ensure that the entire content of the first mixer is inactivated, including droplets on the mixer wall or dead

volume inside tubing, some processes are operated using 3 single-use mixing bags:

- 1 for low pH viral inactivation
- 1 for neutralisation
- 1 for homogenization of the filtered drug substance.

Some processes are operated with two single-use mixing bags by combining the 2 mixing steps, low pH inactivation and neutralisation, into the same single-use mixing bag.

PDS for Low pH virus inactivation and neutralisation are designed with:

- Fully closed 8" diameter top port for maintaining aseptic conditions during mixing.
- Integrated single-use pH sensor and thermowell for in-line monitoring and control of the inactivation process.
- Top lines with TuFlux® Silicone tubing and quick coupler connector for pH adjustment.
- Bottom lines with TuFlux® Silicone tubing and Tri-Clamp 1½" sanitary flange for filling and draining.
- Bottom lines with TuFlux® Silicone tubing and clave needleless port for sterile sampling.



The following options are also available:

- Lines for other liquid additions with TuFlux® Silicone tubing and quick coupler connector.
- Drain valves to avoid hold up volumes into the tubes.

PDS for post filtration are designed with:

- Integrated thermowell for temperature monitoring and control.
- A combined TuFlux® Silicone + TuFlux® TPE tubing ended by an Opta® SFT female to allow sterile connection and disconnection of the adequate filter line.
- A combined TuFlux® Silicone + TuFlux® TPE tubing ended by a Tri-Clamp 1½" sanitary flange for draining.
- Bottom line with TuFlux® Silicone tubing and clave needleless port for sterile sampling.
- Bottom line with TuFlux® Silicone tubing and quick coupler connector for liquid additions.

Downstream Intermediates

pH sensor & Thermowell

Thermowell

No sensor

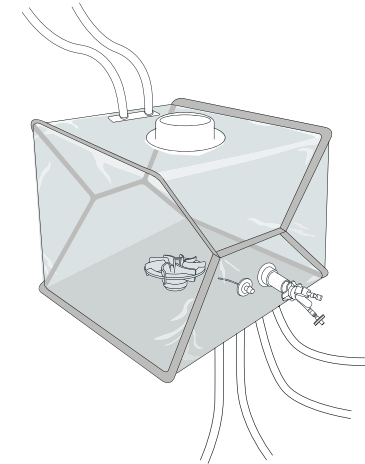

Example of a 200 L mixing bag equipped with pH sensor & Thermowell

Flexsafe® Pro Mixer with pH Sensor and Thermowell for Low pH Viral Inactivation and Neutralisation

Bag Volume	Part Number	Units per Box	Drain Valves	Top Port	Inlet	Outlet	Sampling	Addition 1	Addition 2	pH Adjustment
50 L	FMS500076	1	Yes	Closed 8" Top Port	½" ID TuFlux®	½" ID TuFlux®	¼" ID TuFlux®	When drain valves: 1 top line: ¾" ID TuFlux® Silicone 0.15 m (6") + MPC Female + sealing cap	n/a	2 top lines: ¼" ID TuFlux® Silicone 0.1 m (4") + MPC female + sealing cap
	FMS500077	1	No		½" ID TuFlux® Silicone 1.5 m (60") + ½" Tri-Clamp	½" ID TuFlux® Silicone 1.5 m (60") + ½" Tri-Clamp	¼" ID TuFlux® Silicone 0.1 m (4") + Clave needleless sampling port			
100 L	FMS500078	1	Yes	Closed 8" Top Port	1½" sanitary flange with gasket, cap & union	1½" sanitary flange with gasket, cap & union	¼" ID TuFlux® Silicone 0.1 m (4") + Clave needleless sampling port	When no drain valve: 1 bottom line: ¾" ID TuFlux® Silicone 1.5 m (60") + MPC Female + sealing cap	n/a	2 top lines: ¼" ID TuFlux® Silicone 0.1 m (4") + MPC female + sealing cap
	FMS500079	1	No		1½" sanitary flange with gasket, cap & union	1½" sanitary flange with gasket, cap & union				

[Continue >](#)

Downstream Intermediates

pH sensor & Thermowell

Thermowell

No sensor

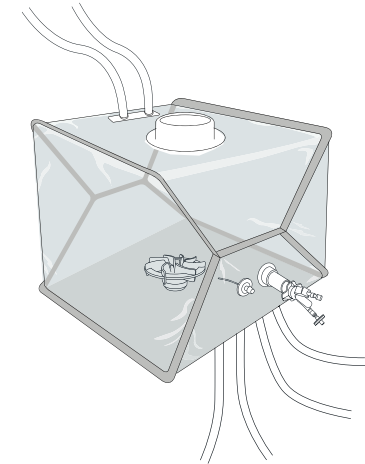

Example of a 200 L mixing bag equipped with pH sensor & Thermowell

Flexsafe® Pro Mixer with pH Sensor and Thermowell for Low pH Viral Inactivation and Neutralisation

Bag Volume	Part Number	Units per Box	Drain Valves	Top Port	Inlet	Outlet	Sampling	Addition 1	Addition 2	pH Adjustment
200 L	FMS500080	2	Yes	Closed 8" Top Port	½" ID TuFlux® Silicone 1.5 m (60") + ½" Tri-Clamp	½" ID TuFlux® Silicone 1.5 m (60") + ½" Tri-Clamp	¼" ID TuFlux® Silicone 0.1 m (4") + Clave needleless sampling port	When drain valves: 1 bottom line: ½" ID TuFlux® Silicone 1.5 m (60") + MPC Female + sealing cap	When drain valves: 1 bottom line: ½" ID TuFlux® Silicone 1.5 m (60") + MPC Female + sealing cap	2 top lines: ¼" ID TuFlux® (4") Silicone 0.1 m + MPC female + sealing cap
	FMS500081	2	No							
400 L	FMS500082	2	Yes		1½" sanitary flange with gasket, cap & union	1½" sanitary flange with gasket, cap & union				
	FMS500083	2	No							
650 L	FMS500084	1	Yes					When no drain valve: 1 bottom line: ¾" ID TuFlux® Silicone 1.5 m (60") + MPC Female + sealing cap	When no drain valve: 1 bottom line: ¾" ID TuFlux® Silicone 1.5 m (60") + MPC Female + sealing cap	
	FMS500085	1	No							
1,000 L	FMS500086	1	Yes							
	FMS500087	1	No							

Downstream Intermediates

pH sensor & Thermowell

Thermowell

No sensor

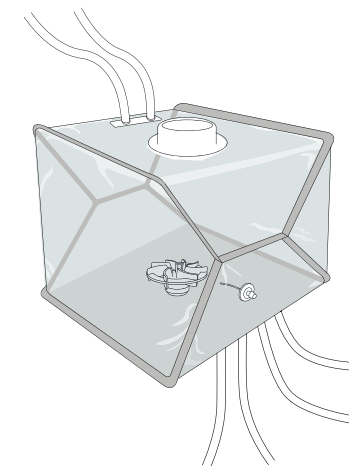

Example of a 200 L mixing bag equipped with Thermowell

Flexsafe® Pro Mixer with Thermowell for Post Filtration

Bag Volume	Part Number	Units per Box	Drain Valves	Top Port	Inlet	Outlet	Sampling	Addition 1	Addition 2	pH Adjustment
50 L	FMS503115	1	No	Closed 8" Top Port	½" ID TuFlux®	½" ID TuFlux®	¼" ID TuFlux®	¾" ID TuFlux®	⅜" ID TuFlux®	n/a
100 L	FMS500095	1	No		Silicone 1 m (40") + ½" ID TuFlux® TPE	Silicone 1 m (40") + ½" ID TuFlux® TPE	Silicone 0.1 m (4") + Clave needleless sampling port	Silicone 1.5 m (60") + MPC Female + sealing cap	Silicone 1.5 m (60") + MPC Female + sealing cap	
200 L	FMS500096	2	No		0.5 m (20") + ½" Opta® SFT female	0.5 m (20") + ½" Tri-Clamp 1½" sanitary flange with gasket, cap & union				
400 L	FMS500097	2	No							
650 L	FMS500098	1	No							
1,000 L	FMS500099	1	No							

Downstream Intermediates

pH sensor & Thermowell

Thermowell

No sensor

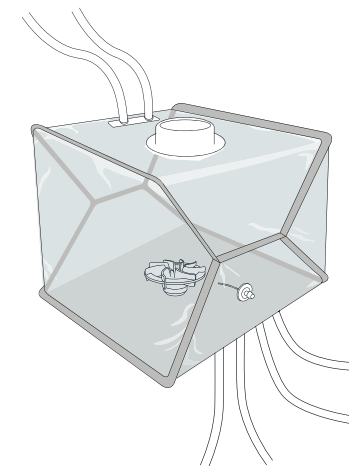

Example of a 200 L mixing bag equipped with Thermowell

Flexsafe® Pro Mixer Without Single-use Sensor

Bag Volume	Part Number	Units per Box	Drain Valves	Top Port	Inlet	Outlet	Sampling	Addition 1	Addition 2	pH Adjustment
5 L	FMS319774	1	No	Opened 4" Top Port	¼" ID TuFlux® Silicone 1.0 m (40")	¼" ID TuFlux® Silicone 1.0 m (40")	¼" ID TuFlux® Silicone 0.100 m + Clave needleless sampling port	n/a	n/a	n/a
10 L	FMS319775	1	No	Top Port with gasket, cap & union	+ 1.5" Tri-Clamp connector with gasket, cap & union	+ 1.5" Tri-Clamp connector with gasket, cap & union				
20 L	FMS319776	1	No	Opened 4" Top Port with gasket, cap & union	¾" ID TuFlux® Silicone 1.0 m (40") + 1.5" Tri-Clamp connector with gasket, cap & union	¾" ID TuFlux® Silicone 1.0 m (40") + 1.5" Tri-Clamp connector with gasket, cap & union	¾" ID TuFlux® Silicone 0.100 m + Clave needleless sampling port	n/a	n/a	n/a

Drug Substance Purification

pH sensor & Thermowell

Thermowell

Flexsafe® Pro Mixer features a levitating impeller to preserve the drug substance during low shear blending applications. PDS are designed with single-use sensors for reliable use along the process steps.

Process samples are taken off-line for other QC tests such as product quality attributes and bioburden prior to sterile filtration.

The Opta® SFT connector or the BioWelder® TC are used for respectively sterile connection or sterile weld.

Tri-Clamp or quick coupler connectors are used for aseptic connections under ISO laminar air flow.

Sterile disconnection is done using the BioSealer® TC.

PDS for mixing during drug substance purification are designed for

- Aseptic filling and draining operations under ISO laminar air flow:
 - bottom lines with TuFlux® Silicone tubing and Tri-Clamp 1½" sanitary flange.
- Integrated single-use pH sensor and | or thermowell for in-line monitoring and control.
- Top lines with TuFlux® Silicone tubing and quick coupler connector for pH adjustment.
- Bottom line with TuFlux® Silicone tubing and clave needleless port for sampling.
- Bottom lines with TuFlux® Silicone tubing and quick coupler connector for liquid additions.
- Fully closed 8" diameter top port for maintaining aseptic conditions during mixing.



Drug Substance Purification

pH sensor & Thermowell

Thermowell

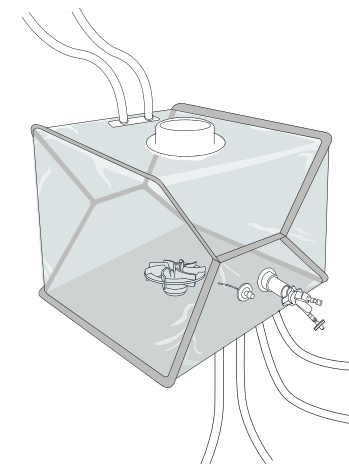

Example of a 200 L mixing bag equipped with pH sensor & Thermowell

Flexsafe® Pro Mixer with pH Sensor & Thermowell

Bag Volume	Part Number	Units per Box	Drain Valves	Top Port	Inlet	Outlet	Sampling	Addition 1	Addition 2	pH Adjustment
50 L	FMS500077	1	No	Closed 8" Top Port	½" ID TuFlux® Silicone 1.5 m (60") + ½" Tri-Clamp	½" ID TuFlux® Silicone 1.5 m (60") + ½" Tri-Clamp	¼" ID TuFlux® Silicone 0.1 m (4") + Clave needleless sampling port	¾" ID TuFlux® Silicone 1.5 m (60") + MPC Female + sealing cap	n/a	2 top lines: ¼" ID TuFlux® Silicone 0.1 m (4") + MPC female + sealing cap
100 L	FMS500079	1	No							
200 L	FMS500081	2	No		1½" sanitary flange with gasket, cap & union	1½" sanitary flange with gasket, cap & union			¾" ID TuFlux® Silicone 1.5 m (60") + MPC Female + sealing cap	
400 L	FMS500083	2	No							
650 L	FMS500085	1	No							
1,000 L	FMS500087	1	No							

Drug Substance Purification

pH sensor & Thermowell

Thermowell

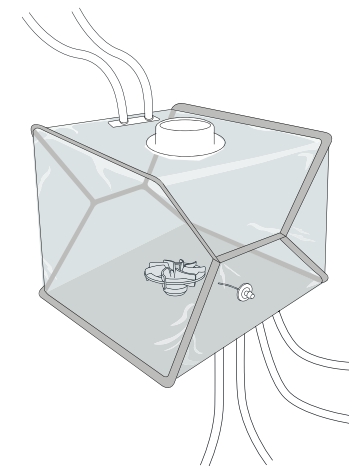

Example of a 200 L mixing bag equipped
with Thermowell

Flexsafe® Pro Mixer with Thermowell

Bag Volume	Part Number	Units per Box	Drain Valves	Top Port	Inlet	Outlet	Sampling	Addition 1	Addition 2	pH Adjustment
50 L	FMS500088	1	No	Closed 8" Top Port	½" ID TuFlux®	½" ID TuFlux®	¼" ID TuFlux®	⅜" ID TuFlux®	⅜" ID TuFlux®	2 top lines: ¼" ID TuFlux® Silicone 0.1 m (4") + MPC female + sealing cap
100 L	FMS500089	1	No		Silicone 1.5 m (60") + ½" Tri-Clamp	Silicone 1.5 m (60") + ½" Tri-Clamp	Silicone 0.1 m (4") + Clave needleless sampling port	Silicone 1.5 m (60") + MPC Female + sealing cap	Silicone 1.5 m (60") + MPC Female + sealing cap	
200 L	FMS500090	2	No		1½" sanitary flange with gasket, cap & union	1½" sanitary flange with gasket, cap & union				
400 L	FMS500091	2	No							
650 L	FMS500092	1	No							
1,000 L	FMS500093	1	No							

Drug Product Formulation

pH sensor & Thermowell

No sensor & with sterile connections and disconnections

No sensor & with aseptic connections and disconnections under ISO laminar air flow

Flexsafe® Pro Mixer features a levitating impeller to preserve the drug product during final formulation. PDS are designed with single-use sensors for reliable use along the process steps.

The drug product formulation involves a mixing step where the product is formulated before final filtration, fill and finish in its final container.

During this step, the drug substance is mixed with other buffers and excipients to obtain the final drug product concentration and composition.

pH is monitored and | or adjusted in-line and samples are taken off-line for other QC tests such as product quality attributes and bioburden prior to sterile filtration.

Flexsafe® Pro Mixer PDS for final formulation are available in:

- With single-use and integrated sensors for in-line pH and temperature monitoring and adjustment required for your cGMP biomanufacture.
- Without single-use sensors where sterile samples are taken for off-line controls.

PDS are designed for either sterile or aseptic connections and disconnections.

The Opta® SFT connector or the BioWelder® TC are used for respectively sterile connection or sterile weld.

Tri-Clamp or quick coupler connectors are used for aseptic connections under ISO laminar air flow.

Sterile disconnection is done using the BioSealer® TC.

Intelligent PDS for final formulation are designed with:

- Bottom lines with a combined TuFlux® Silicone + TuFlux® TPE tubing ended by an Opta® SFT connector to allow pumping and sterile weld and | or seal
- Integrated single-use pH sensor and thermo-well for in-line monitoring and control
- Top lines with TuFlux® Silicone tubing and Opta® SFT connector for sterile pH adjustment
- Bottom line with TuFlux® Silicone tubing and clave needleless port for sterile sampling
- Bottom or top line with TuFlux® Silicone tubing and Opta® SFT connector for sterile liquid additions
- Fully closed 8" diameter top port for sterile mixing



Flexsafe® Pro Mixer PDS without sensor for final formulation are designed for:

- Aseptic operations under ISO laminar air flow:
 - filling and draining lines with TuFlux® Silicone tubing and Tri-Clamp 1 ½" sanitary flange
 - additions and pH adjustment lines with TuFlux® Silicone tubing and quick coupler connector
 - sampling line with TuFlux® tubing and clave needleless port
- For sterile operations:
 - filling and draining lines with a combined TuFlux® Silicone and TuFlux® TPE tubing ended by an Opta® SFT connector
 - pH adjustment top lines with TuFlux® Silicone tubing ended by Opta® SFT connector
 - sampling line with a clave needleless port
 - liquid addition lines with TuFlux® Silicone tubing ended by Opta® SFT connector
- Fully closed 8" diameter top port for sterile mixing.

Options with drain valves to avoid hold up volumes into the tubes are also available.

Drug Product Formulation

pH sensor & Thermowell

No sensor & with sterile connections and disconnections

No sensor & with aseptic connections and disconnections under ISO laminar air flow

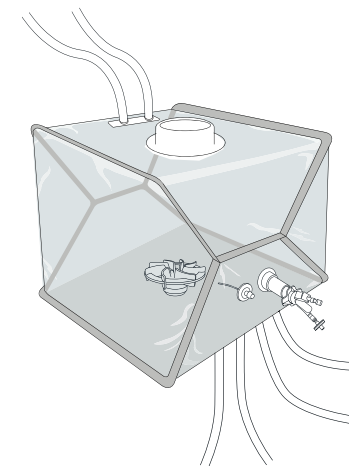

Example of a 200 L mixing bag equipped with pH sensor & Thermowell

Flexsafe® Pro Mixer with pH Sensor & Thermowell

Bag Volume	Part Number	Units per Box	Drain Valves	Top Port	Inlet	Outlet	Sampling	Addition 1	Addition 2	pH Adjustment
50 L	FMS500114	1	Yes	Closed 8" Top Port	½" TuFlux®	½" ID TuFlux®	¼" ID TuFlux® Silicone 0.1 m (4") + Clave needleless sampling port	When drain valves:	n/a	2 top lines: ¼" ID TuFlux® Silicone 0.1 m (4") + ¼" Opta® SFT female
	FMS500115	1	No		½" ID TuFlux® + ½" ID TuFlux®	½" ID TuFlux® + ½" ID TuFlux®		1 top line: ¾" ID TuFlux®		
100 L	FMS500116	1	Yes		TPE 0.5 m (20") + ½" Opta® SFT female	TPE 0.5 m (20") + ½" Opta® SFT male		Silicone 0.15 m (6") + ¾" Opta® SFT female		
	FMS500117	1	No							

[Continue >](#)

Drug Product Formulation

pH sensor & Thermowell

No sensor & with sterile connections and disconnections

No sensor & with aseptic connections and disconnections under ISO laminar air flow

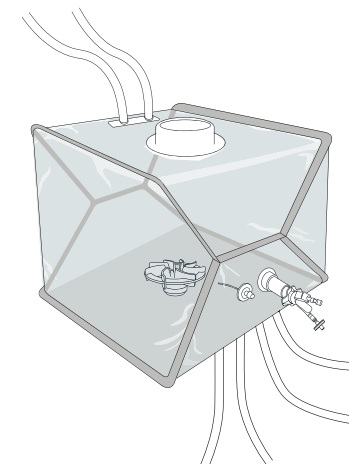

Example of a 200 L mixing bag equipped with pH sensor & Thermowell

Flexsafe® Pro Mixer with pH Sensor & Thermowell

Bag Volume	Part Number	Units per Box	Drain Valves	Top Port	Inlet	Outlet	Sampling	Addition 1	Addition 2	pH Adjustment
200 L	FMS500118	2	Yes	Closed 8" Top Port	½" TuFlux®	½" ID TuFlux®	¼" ID TuFlux® Silicone 0.1 m (4") + Clave needleless sampling port	When drain valves: 1 bottom line: ½" ID TuFlux®	When drain valves: 1 bottom line: ½" ID TuFlux®	2 top lines: ¼" ID TuFlux® Silicone 0.1 m (4") + ¼" Opta® SFT female
	FMS500119	2	No		Silicone 1 m (40") + ½" ID TuFlux®	Silicone 1 m (40") + ½" ID TuFlux®		Silicone 1.5 m (60") + ½" Opta® SFT female	Silicone 1.5 m (60") + ½" Opta® SFT female	
400 L	FMS500120	2	Yes		TPE 0.5 m (20") + ½" Opta® SFT female	TPE 0.5 m (20") + ½" Opta® SFT male				
	FMS500121	2	No							
650 L	FMS500122	1	Yes					When no drain valve: 1 bottom line: ¾" ID TuFlux®	When no drain valve: 1 bottom line: ¾" ID TuFlux®	
	FMS500123	1	No						Silicone 1.5 m (60") + ¾" Opta® SFT female	Silicone 1.5 m (60") + ¾" Opta® SFT female
1,000 L	FMS500124	1	Yes							
	FMS500125	1	No							

Drug Product Formulation

pH sensor & Thermowell

No sensor & with sterile connections and disconnections

No sensor & with aseptic connections and disconnections under ISO laminar air flow

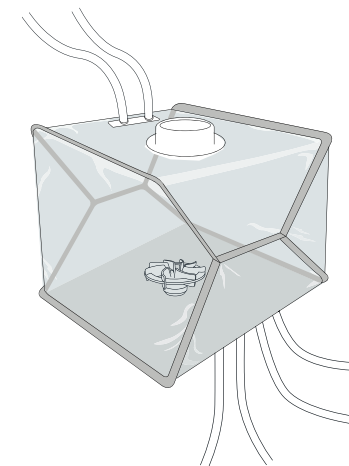

Example of a 200 L mixing bag without single-use sensor and with sterile connections and disconnections

Flexsafe® Pro Mixer Without Single-use Sensor and With Sterile Connections and Disconnections

Bag Volume	Part Number	Units per Box	Drain Valves	Top Port	Inlet	Outlet	Sampling	Addition 1	Addition 2	pH Adjustment
50 L	FMS500126	1	Yes	Closed 8" Top Port	½" TuFlux®	½" ID TuFlux®	¼" ID TuFlux®	When drain valves: 1 top line:	When drain valves: 1 top line:	n/a
	FMS500127	1	No		Silicone 1 m (40") + ½" ID TuFlux®	Silicone 1 m (40") + ½" ID TuFlux®	Silicone 0.1 m (4") + Clave needleless sampling port	¾" ID TuFlux®	¾" ID TuFlux®	
100 L	FMS500128	1	Yes		TPE 0.5 m (20") + ½" Opta® SFT female	TPE 0.5 m (20") + ½" Opta® SFT male		Silicone 0.15 m (6") + ¾" Opta® SFT female	Silicone 0.15 m (6") + ¾" Opta® SFT female	
	FMS500129	1	No					When no drain valve: 1 bottom line: ¾" ID TuFlux® Silicone 1.5 m (60") + ¾" Opta® SFT female	When no drain valve: 1 bottom line: ¾" ID TuFlux® Silicone 1.5 m (60") + ¾" Opta® SFT female	

[Continue >](#)

Drug Product Formulation

pH sensor & Thermowell

No sensor & with sterile connections and disconnections

No sensor & with aseptic connections and disconnections
under ISO laminar air flow

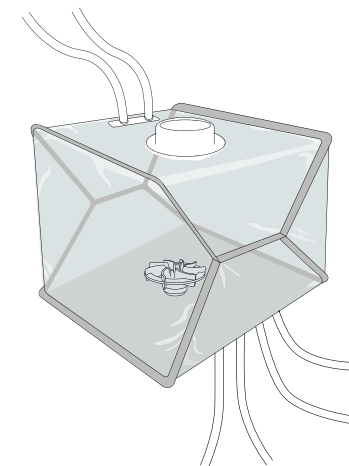

Example of a 200 L mixing bag without single-use sensor and with sterile connections and disconnections

Flexsafe® Pro Mixer Without Single-use Sensor and With Sterile Connections and Disconnections

Bag Volume	Part Number	Units per Box	Drain Valves	Top Port	Inlet	Outlet	Sampling	Addition 1	Addition 2	pH Adjustment
200 L	FMS500130	2	Yes	Closed 8" Top Port	½" TuFlux® Silicone 1 m (40") + ½" ID TuFlux®	½" ID TuFlux® Silicone 1 m (40") + ½" ID TuFlux®	¼" ID TuFlux® Silicone 0.1 m (4") + Clave needleless sampling port	When drain valves: 1 bottom line: ½" ID TuFlux® Silicone 1.5 m (60") + ½" Opta® SFT female	When drain valves: 1 bottom line: ½" ID TuFlux® Silicone 1.5 m (60") + ½" Opta® SFT female	n/a
	FMS500131	2	No							
400 L	FMS500132	2	Yes		TPE 0.5 m (20") + ½" Opta® SFT female	TPE 0.5 m (20") + ½" Opta® SFT male		When no drain valve: 1 bottom line: ¾" ID TuFlux® Silicone 1.5 m (60") + ¾" Opta® SFT female	When no drain valve: 1 bottom line: ¾" ID TuFlux® Silicone 1.5 m (60") + ¾" Opta® SFT female	
	FMS500133	2	No							
650 L	FMS500134	1	Yes					When no drain valve: 1 bottom line: ¾" ID TuFlux® Silicone 1.5 m (60") + ¾" Opta® SFT female	When no drain valve: 1 bottom line: ¾" ID TuFlux® Silicone 1.5 m (60") + ¾" Opta® SFT female	
	FMS500135	1	No							
1,000 L	FMS500136	1	Yes					When no drain valve: 1 bottom line: ¾" ID TuFlux® Silicone 1.5 m (60") + ¾" Opta® SFT female	When no drain valve: 1 bottom line: ¾" ID TuFlux® Silicone 1.5 m (60") + ¾" Opta® SFT female	
	FMS500137	1	No							

Drug Product Formulation

pH sensor & Thermowell

No sensor & with sterile connections and disconnections

No sensor & with aseptic connections and disconnections under ISO laminar air flow

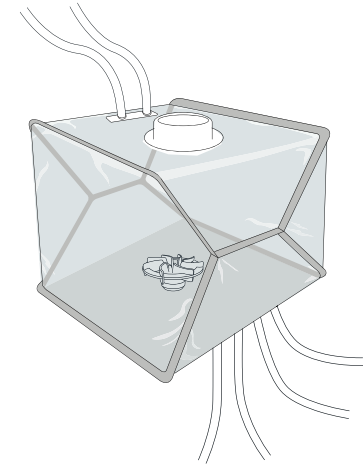

Example of a 200 L mixing bag without single-use sensor and with aseptic connections and disconnections under ISO laminar air flow

Flexsafe® Pro Mixer Without Single-use Sensor and With Aseptic Connections and Disconnections under ISO Laminar Air Flow

Bag Volume	Part Number	Units per Box	Drain Valves	Top Port	Inlet	Outlet	Sampling	Addition 1	Addition 2	pH Adjustment
50 L	FMS500100	1	Yes	Closed 8" Top Port	½" ID TuFlux®	½" ID TuFlux®	¼" ID TuFlux®	When drain valves: 1 top line: ⅜" ID TuFlux® Silicone 0.15 m (6") + MPC Female + sealing cap	When drain valves: 1 top line: ⅜" ID TuFlux® Silicone 0.15 m (6") + MPC Female + sealing cap	n/a
	FMS500101	1	No		½" ID TuFlux® + ½" Tri-Clamp	½" ID TuFlux® + ½" Tri-Clamp	¼" ID TuFlux® + Clave needleless sampling port			
100 L	FMS500102	1	Yes		1½" sanitary flange with gasket, cap & union	1½" sanitary flange with gasket, cap & union		When no drain valve: 1 bottom line: ⅜" ID TuFlux® Silicone 1.5 m (60") + MPC Female + sealing cap	When no drain valve: 1 bottom line: ⅜" ID TuFlux® Silicone 1.5 m (60") + MPC Female + sealing cap	
	FMS500103	1	No		1½" sanitary flange with gasket, cap & union	1½" sanitary flange with gasket, cap & union				

[Continue >](#)

Drug Product Formulation

pH sensor & Thermowell

No sensor & with sterile connections and disconnections

No sensor & with aseptic connections and disconnections under ISO laminar air flow

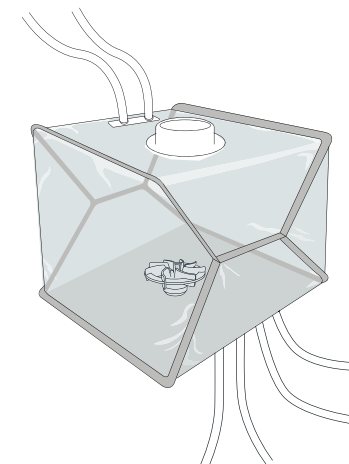

Example of a 200 L mixing bag without single-use sensor and with aseptic connections and disconnections under ISO laminar air flow

Flexsafe® Pro Mixer Without Single-use Sensor and With Aseptic Connections and

Bag Volume	Part Number	Units per Box	Drain Valves	Top Port	Inlet	Outlet	Sampling	Addition 1	Addition 2	pH Adjustment
200 L	FMS500104	2	Yes	Closed 8" Top Port	½" ID TuFlux® Silicone 1.5 m (60") + ½" Tri-Clamp	½" ID TuFlux® Silicone 1.5 m (60") + ½" Tri-Clamp	¼" ID TuFlux® Silicone 0.1 m (4") + Clave needleless sampling port	When drain valves:	When drain valves:	n/a
	FMS500105	2	No					1 bottom line: ½" ID TuFlux®	1 bottom line: ½" ID TuFlux®	
400 L	FMS500106	2	Yes		1½" sanitary flange with gasket, cap & union	1½" sanitary flange with gasket, cap & union		Silicone 1.5 m (60")	Silicone 1.5 m (60")	
	FMS500107	2	No					+ MPC Female + sealing cap	+ MPC Female + sealing cap	
650 L	FMS500108	1	Yes						When no drain valve:	When no drain valve:
	FMS500109	1	No						1 bottom line: ¾" ID TuFlux®	1 bottom line: ¾" ID TuFlux®
1,000 L	FMS500110	1	Yes					Silicone 1.5 m (60")	Silicone 1.5 m (60")	
	FMS500111	1	No					+ MPC Female + sealing cap	+ MPC Female + sealing cap	

Hardware

Flexsafe® Pro Mixer Small Volume

Flexsafe® Pro Mixer 5L | 10L | 20L

Flexsafe® Pro Mixer Base Unit

Flexsafe® Pro Mixer Bag Holders and Accesories



Flexsafe® Pro Mixer 5 L | 10 L | 20 L

Part number	Volume in L	Description	Quantity
PRO-MIXER-SV	5 10 20	Flexsafe® Pro Mixer 5 L 10 L 20 L	1
	n/a	Flexsafe® Pro Mixer Base Unit	1
	5	Flexsafe® Pro Mixer Bag Holder 5 L	1
	10	Flexsafe® Pro Mixer Bag Holder 10 L	1
	20	Flexsafe® Pro Mixer Bag Holder 20 L	1

Flexsafe® Pro Mixer 5 L | 10 L | 20 L accessories

Part number	Volume in L	Description	Quantity
FXC301595	5 10 20	Flexsafe® Pro Mixer Tube Holder 5/8"	1
FXC301596	5 10 20	Flexsafe® Pro Mixer Tube Holder 7/8"	1
FXC301598	5 10 20	Flexsafe® Pro Mixer Lab Cart 650mm	1



Flexsafe® Pro Mixer 5 L



Flexsafe® Pro Mixer 10 L



Flexsafe® Pro Mixer 20 L

Hardware

Flexsafe® Pro Mixer Small Volume

Flexsafe® Pro Mixer 5L | 10L | 20L

Flexsafe® Pro Mixer Base Unit

Flexsafe® Pro Mixer Bag Holders and Accesories

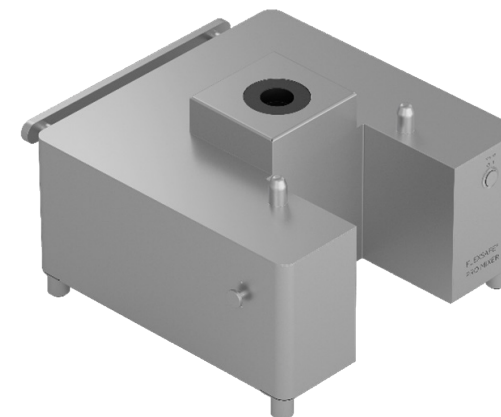

Flexsafe® Pro Mixer Base Unit – Facility

Description	Technical Specification
Dimensions (W × L × H) [mm]	468 × 452 × 244
Weight [kg]	11.5
Material of construction	Stainless steel AISI 304, 1.4301 labels PET / PVC gaskets EPDM / silicone
Surface finish	Bead blasted and passivated with a max. surface roughness of Ra 1.2
Operational footprint [mm]	867 × 671 with a minimum of 400 × 500
IP rating	54
Noise from operator position [dB]	70
Max humidity [%]	80
Operating Temperature [°C]	2 – 30
Impeller type	Saturn
Mixing speed [rpm]	0 – 750

Flexsafe® Pro Mixer Base Unit – Utilities

Description	Technical Specification
Electrical supply [V]	100 – 240
Mains input	1 ph. / N / PE
Frequency [Hz]	50/60
Max. power consumption [A]	0.84
Max. mains voltage fluct. [%]	± 10
Overvoltage cat. IEC60664-1	Type 2
Short circuit current rating [kA]	5
Interf. immunity IEC61326-1	B class
Motor power[W]	50

[Continue >](#)

Hardware

Flexsafe® Pro Mixer Small Volume

Flexsafe® Pro Mixer 5L | 10L | 20L

Flexsafe® Pro Mixer Base Unit

Flexsafe® Pro Mixer Bag Holders and Accesories

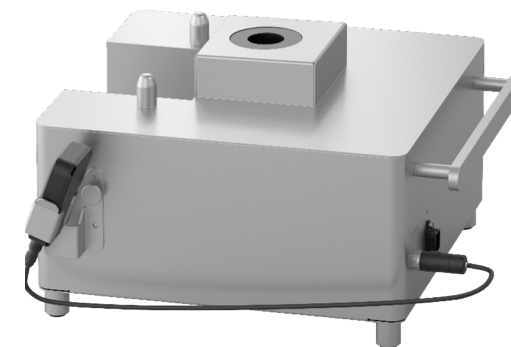

Flexsafe® Pro Mixer Base Unit – Control System

Description	Technical Specification
Control architecture	Speed control via external user panel: operation via buttons on user panel. Remote speed control signal and speed feedback signal: signal cable uses the same port as the user panel.
Power plug type	F, B, G, H, I, J, D/M, N,
Remote control connector	- Connector: 15 pin "Series 915 TE Connectivity" - 13 pins being occupied (analog, digital, RS485, ground, etc.), 2 pins open as power supply internally - Analog In: Mixer Setpoint (4...20 mA) - Analog Out: Actual speed (0-10V) - Digital In1: Enable (5-24V = active; 0V = not active) - Digital In2: Reset (5-24V = active; 0V = not active) - Digital Out1: Status - Digital Out2: Error

Flexsafe® Pro Mixer Base Unit – Electrical Safety

Description	Technical Specification
CE	Safety of electrical equipment, according to EN 61326-1 Electrical equipment for measurement, control, and laboratory use – EMC requirements – Part 1: General requirements (IEC 61326-1)
UL	UL 61010-1 UL 61010-2-010

Hardware

Flexsafe® Pro Mixer Small Volume

Flexsafe® Pro Mixer 5L | 10L | 20L

Flexsafe® Pro Mixer Base Unit

Flexsafe® Pro Mixer Bag Holders and Accesories



Flexsafe® Pro Mixer Bag Holder 5L | 10L | 20L

Description	Bag Holder 5 L	Bag Holder 10 L	Bag Holder 20 L
Dimensions (W × L × H) [mm]	275 × 299 × 240	315 × 339 × 276	377 × 401 × 341
Weight [kg]	6.5	8.6	12.6
Material of construction	Stainless steel AISI 304, 1.4301 Windows PC handle POM / PA gaskets EPDM		
Surface finish	Bead blasted and passivated with a max. surface roughness of Ra 1.2		
Nominal filling volume [L]	5.00	10	20
Max. overfilling volume [L]	5.50	11	22
Max. filling weight [kg]	7.15	13	26
Operating temperature [°C]	2 - 30		

Flexsafe® Pro Mixer Tube Holder 5/8" and 7/16"

Description	Tube Holder 5/8"	Tube Holder 7/16"
Dimensions (W × L × H) [mm]	70 × 115 × 67	70 × 115 × 67
Weight [kg]	0.18	0.18
Material of construction	Stainless steel AISI 304	
Surface finish	Bead blasted and passivated with a max. surface roughness of Ra 1.2	

Flexsafe® Pro Mixer Lab Cart 650mm

Description	Technical Specification
Dimensions (W × L × H) [mm]	578 × 1 149 × 1 021
Weight [kg]	36
Material of construction	Stainless steel AISI 304 (main); incl. PC, POM, PA, EPDM, iglidur J, PET, PVC, silicone elastomer; (electronic components excluded)
Surface finish	Bead blasted and passivated, Ra ≤ 1,2
Max humidity [%]	80
Ambient temperature [°C]	2 - 30

Hardware

Palletank for Mixing

Single-Walled

With Weighing

Jacketed

Jacketed with Weighing

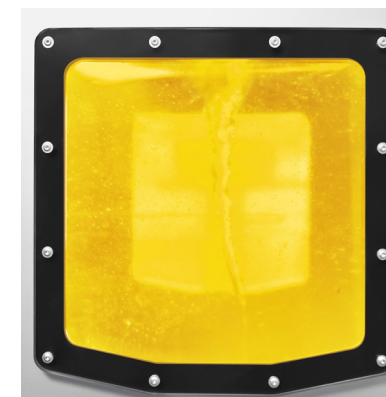

Description	Volumes	Technical Specification
Volumes		50 L 100 L 200 L 400 L 650 L 1,500 L 2,000 L 2,500 L 3,000 L
Main construction materials	50 L to 3,000 L	Stainless Steel 304L
	50 L to 1,000 L	Windows made of PC and EPDM sealing
Surface finish	50 L to 3,000 L	Acid cleaned, stainless steel bead blasted and passivated
Door	50 L to 400 L	Front hinged door and PC windows
	650 L and 1,000 L	Front hinged doors and PC windows
	1,500 L to 3,000 L	Front and lateral hinged doors
Bag tubing gate	50 L to 3,000 L	Front bottom port for bag lines sensor access
Port	50 L to 3,000 L	Railed port for drive unit coupling
Mobility	50 L to 1,000 L	Mounted on stainless cart with four clean room wheels and push handles
	1,500 L to 3,000 L	Mounted on stainless cart with four clean room fixed feet
Minimum door height	1,500 L to 3,000 L	1,550 mm
Minimum ceiling height	1,500 L	3,000 mm
	2,000 L	3,500 mm
	2,500 L	4,000 mm
	3,000 L	4,500 mm
Operating temperature	50 L to 3,000 L	0°C to 50°C

Hardware

Palletank
for Mixing

Single-Walled

With Weighing

Jacketed

Jacketed with Weighing



Palletank for Mixing

Dimensions and Weight
European Version (Metric Units)

Part Number	Volume	Dimensions (approx.) W×D×H	Net Weight	Max. Gross Weight
FXC301951	50 L	785×705×989 mm	78 kg	401 kg
FXC301952	100 L	785×705×1,094 mm	86 kg	469 kg
FXC301953	200 L	785×705×1,194 mm	105 kg	621 kg
FXC301954	400 L	1,031×873×1,344 mm	142 kg	904 kg
FXC301955	650 L	1,181×1,008×1,454 mm	175 kg	1,288 kg
FXC301956	1,000 L	1,296×1,157×1,654 mm	256 kg	1,766 kg
FXC301958	1,500 L	1,600×1,076×2,444 mm	465 kg	2,640 kg
FXC301959	2,000 L	1,600×1,076×2,944 mm	528 kg	3,316 kg
FXC301960	2,500 L	1,600×1,076×3,445 mm	592 kg	4,005 kg
FXC301961	3,000 L	1,600×1,076×3,945 mm	656 kg	4,671 kg

Dimensions and Weight
North American Version (Imperial Units)

Part Number	Volume	Dimensions (approx.) W×D×H	Net Weight	Max. Gross Weight
FXC301973	50 L	785×705×989 mm	78 kg	401 kg
FXC301974	100 L	785×705×1,094 mm	86 kg	469 kg
FXC301975	200 L	785×705×1,194 mm	105 kg	621 kg
FXC301976	400 L	1,031×873×1,344 mm	142 kg	904 kg
FXC301977	650 L	1,181×1,008×1,454 mm	175 kg	1,288 kg
FXC301978	1,000 L	1,296×1,157×1,654 mm	256 kg	1,766 kg
FXC301980	1,500 L	1,600×1,076×2,444 mm	465 kg	2,640 kg
FXC301981	2,000 L	1,600×1,076×2,944 mm	528 kg	3,316 kg
FXC301982	2,500 L	1,600×1,076×3,445 mm	592 kg	4,005 kg
FXC301983	3,000 L	1,600×1,076×3,945 mm	656 kg	4,671 kg

Hardware

Pallettank for Mixing

Single-Walled

With Weighing

Jacketed

Jacketed with Weighing

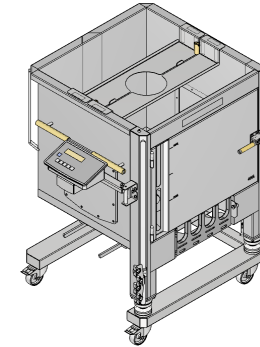

Pallettank for Mixing with Weighing

Pallettank for Mixing with Weighing

Description	Technical Specification
Scale Indicator	Minebea Combics 1
Material of construction	Stainless Steel 304
Keyboard	6 keys
Display	14 segments
20 mm weight readout	650 L
Interface	RS232
IP protection rate	IP69K
Operating temperature range	-10°C to 40°C
Integrated load cells	Weighing module Minebea Novego
Material of construction	304 and 4418 (sensor)
IP protection rate	IP68 + IP69
Overload	High overload protection
Vibration resistance	Resistance against oscillations (IEC 68-2-6 Fc); 20g, 100h, 10 to 150 Hz
Design	In accordance with European Hygienic Engineering and Design Group (EHEDG) guidelines
Lift-off	Lift-off protector and anti-wobbling mechanism

Weighing Characteristics

Volumes	Maximum net capacity	Resolution	Accuracy
50 L	78 kg	20 g	60 g
100 L	138 kg	20 g	60 g
200 L	270 kg	50 g	150 g
400 L	516 kg	100 g	300 g
650 L	864 kg	200 g	600 g
1,000 L	1,260 kg	200 g	600 g
1,500 L	1,824 kg	500 g	1,000 g
2,000 L	2,436 kg	500 g	1,000 g
2,500 L	3,060 kg	1,000 g	2,000 g
3,000 L	3,660 kg	1,000 g	2,000 g

Weighing Characteristic calculation method:

Maximum net capacity

- Max fill volume (aseptic conditions) times worst-case 1.2 specific gravity

Resolution

- Estimated deviations = $\frac{1}{2}$ of 10,000 theoretical deviations for Novego load cell: 5,000 deviations
- Practical resolution = Maximum net capacity divided by estimated deviations (5000)
- Final values are rounded based on the Combics weight indicator's ability to display digits 1, 2, or 5 only

Accuracy

- $3 \times$ Resolution for portable tanks and $2 \times$ Resolution for fixed tanks

NOTE: These are theoretical estimated values derived using the method above. Real world performance depends on a number of factors and can be optimized by employing best practices to minimize error from outside sources.

Hardware

Palletank for Mixing

Single-Walled

With Weighing

Jacketed

Jacketed with Weighing



Palletank for Mixing

Dimensions and Weight European Version (Metric Units)

Part Number	Volume	Dimensions (approx.) W×D×H	Net Weight	Max. Gross Weight
FXC301962	50 L	878×705×1,018 mm	81 kg	404 kg
FXC301963	100 L	921×705×1,115 mm	90 kg	473 kg
FXC301964	200 L	981×705×1,194 mm	108 kg	624 kg
FXC301965	400 L	1,159×873×1,344 mm	145 kg	907 kg
FXC301966	650 L	1,311×1,008×1,454 mm	178 kg	1,291 kg
FXC301967	1,000 L	1,426×1,157×1,654 mm	259 kg	1,769 kg
FXC301968	1,500 L	1,720×1,076×2,444 mm	469 kg	2,644 kg
FXC301969	2,000 L	1,720×1,076×2,944 mm	533 kg	3,321 kg
FXC301970	2,500 L	1,720×1,076×3,445 mm	596 kg	4,009 kg
FXC301971	3,000 L	1,720×1,076×3,945 mm	660 kg	4,675 kg

Dimensions and Weight North American Version (Imperial Units)

Part Number	Volume	Dimensions (approx.) W×D×H	Weight	Max. Gross Weight
FXC301984	50 L	878×705×1,018 mm	81 kg	404 kg
FXC301985	100 L	921×705×1,115 mm	90 kg	473 kg
FXC301986	200 L	981×705×1,194 mm	108 kg	624 kg
FXC301987	400 L	1,159×873×1,344 mm	145 kg	907 kg
FXC301988	650 L	1,311×1,008×1,454 mm	178 kg	1,291 kg
FXC301989	1,000 L	1,426×1,157×1,654 mm	259 kg	1,769 kg
FXC301990	1,500 L	1,720×1,076×2,444 mm	469 kg	2,644 kg
FXC301991	2,000 L	1,720×1,076×2,944 mm	533 kg	3,321 kg
FXC301992	2,500 L	1,720×1,076×3,445 mm	596 kg	4,009 kg
FXC301993	3,000 L	1,720×1,076×3,945 mm	660 kg	4,675 kg

Hardware

Pallettank for Mixing

Single-Walled

With Weighing

Jacketed

Jacketed with Weighing

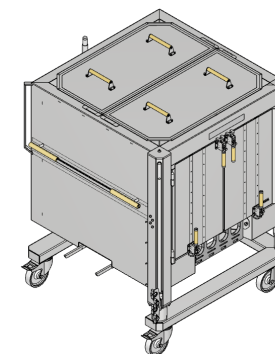

Pallettank for Mixing Jacketed

Pallettank Jacketed

Description	Technical Specification		
		Version: PED (for Europe, Asia and NEMA)	Version: ASME (for North America)
Volumes		50 L 100 L 200 L 400 L 650 L 1,500 L 2,000 L 2,500 L 3,000 L	
Main construction materials	50 L to 3,000 L	Stainless Steel 304L, Perlit Balls (insulation)	Stainless Steel 304L, Foam Glass and Ceramic Fiber (insulation)
Surface finish	50 L to 3,000 L	Acid cleaned, stainless steel bead blasted and passivated	
Door	50 L 100 L	No door	
	200 L 400 L	Front insulated hinged door	
	650 L to 3,000 L	Front insulated hinged doors	
Bag tubing gate	50 L to 3,000 L	Hinged PTFE bottom door	Hinged UHMW bottom door
Port	50 L to 3,000 L	Railed port for drive unit coupling	
Mobility	50 L to 1,000 L	Mounted on stainless cart with four clean room wheels and push handles	
	1,500 L to 3,000 L	Mounted on stainless cart with four clean room fixed feet	
Minimum door height	1,500 L to 3,000 L	2,070 mm	
Minimum ceiling height	1,500 L	3,000 mm	
	2,000 L	3,500 mm	
	2,500 L	4,000 mm	
	3,000 L	4,500 mm	

Hardware



**Palletank
for Mixing**

Single-Walled

With Weighing

Jacketed

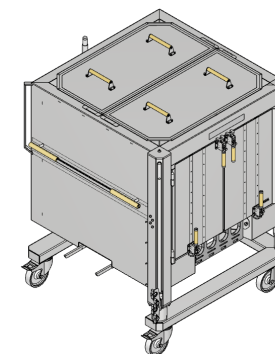
Jacketed with Weighing



Palletank for Mixing Jacketed

Palletank Jacketed

Description	Technical Specification		
		Version: PED (for Europe, Asia and NEMA)	Version: ASME (for North America)
Operating temperature	50 L to 3,000 L	0°C to 50°C	
Working pressure	50 L to 3,000 L	-1 to 6 bars	10 bars
Test pressure	50 L to 3,000 L	9 bars	13 bars
Compliance	50 L to 3,000 L	PED	Heat exchanger ASME certified From heat exchanger: designed and build under ASME code
Insulated	50 L to 3,000 L	On all sides, the bottom and the lids	
Jacketed	50 L and 100 L	4 sides and bottom	
	200 L to 1,000 L	3 sides and bottom	
	1,500 L to 3,000 L	3 sides and bottom for 1,500 L base, module and top insulated only	
Inlet outlet of heat transfer fluid	50 L to 3,000 L	Manual ¼ ball valve and ¼ Tri-Clamp	Male NPT connection

Hardware

Pallettank for Mixing

Single-Walled

With Weighing

Jacketed

Jacketed with Weighing

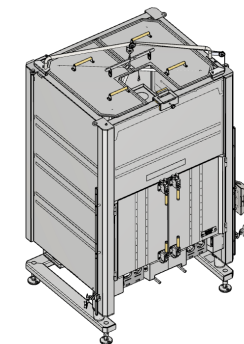

Pallettank for Mixing Jacketed

Dimensions and Weight PED Version (for Europe, Asia and NEMA)

Part Number	Volume	Dimensions (approx.) W×D×H	Net Weight	Max. Gross Weight
FXC301930	50 L	847×817×1,045 mm	118 kg	441 kg
FXC301931	100 L	878×817×1,150 mm	178 kg	561 kg
FXC301932	200 L	949×969×1,250 mm	238 kg	754 kg
FXC301933	400 L	1,158×1,186×1,399 mm	347 kg	1,109 kg
FXC301934	650 L	1,242×1,319×1,509 mm	456 kg	1,569 kg
FXC301935	1,000 L	1,376×1,435×1,710 mm	592 kg	2,102 kg
FXC301936	1,500 L	1,700×1,135×2,530 mm	791 kg	2,966 kg
FXC301937	2,000 L	1,700×1,135×3,050 mm	933 kg	3,721 kg
FXC301938	2,500 L	1,700×1,135×3,570 mm	1,076 kg	4,489 kg
FXC301939	3,000 L	1,700×1,135×4,090 mm	1,218 kg	5,233 kg

Dimensions and Weight ASME Version (North America)

Part Number	Volume	Dimensions (approx.) W×D×H	Net Weight	Max. Gross Weight
FXC301994	50 L	847×817×1,045 mm	118 kg	441 kg
FXC301995	100 L	878×817×1,150 mm	178 kg	561 kg
FXC301996	200 L	949×969×1,250 mm	238 kg	754 kg
FXC301997	400 L	1,158×1,186×1,399 mm	347 kg	1,109 kg
FXC301998	650 L	1,242×1,319×1,509 mm	456 kg	1,569 kg
FXC301999	1,000 L	1,376×1,435×1,710 mm	592 kg	2,102 kg
FXC302000	1,500 L	1,700×1,135×2,530 mm	791 kg	2,966 kg
FXC302001	2,000 L	1,700×1,135×3,050 mm	933 kg	3,721 kg
FXC302002	2,500 L	1,700×1,135×3,570 mm	1,076 kg	4,489 kg
FXC302003	3,000 L	1,700×1,135×4,090 mm	1,218 kg	5,233 kg

Hardware

Palletank
for Mixing

Single-Walled

With Weighing

Jacketed

Jacketed with Weighing

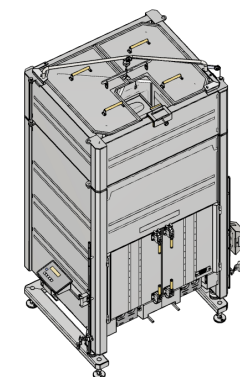

Palletank for Mixing Jacketed with Weighing

Dimensions and Weight PED Version
(for Europe, Asia and NEMA)

Part Number	Volume	Dimensions (approx.) W×D×H	Net Weight	Max. Gross Weight
FXC301940	50 L	970×817×1,058 mm	121 kg	444 kg
FXC301941	100 L	1,013×817×1,150 mm	181 kg	564 kg
FXC301942	200 L	1,112×969×1,250 mm	241 kg	757 kg
FXC301943	400 L	1,287×1,186×1,399 mm	350 kg	1,112 kg
FXC301944	650 L	1,412×1,319×1,509 mm	459 kg	1,572 kg
FXC301945	1,000 L	1,511×1,435×1,710 mm	595 kg	2,105 kg
FXC301946	1,500 L	1,900×1,135×2,530 mm	794 kg	2,969 kg
FXC301947	2,000 L	1,900×1,135×3,050 mm	936 kg	3,724 kg
FXC301948	2,500 L	1,900×1,135×3,570 mm	1,079 kg	4,492 kg
FXC301949	3,000 L	1,900×1,135×4,090 mm	1,221 kg	5,236 kg

Dimensions and Weight ASME Version
(North America)

Part Number	Volume	Dimensions (approx.) W×D×H	Net Weight	Max. Gross Weight
FXC302004	50 L	970×817×1,058 mm	121 kg	444 kg
FXC302005	100 L	1,013×817×1,150 mm	181 kg	564 kg
FXC302006	200 L	1,112×969×1,250 mm	241 kg	757 kg
FXC302007	400 L	1,287×1,186×1,399 mm	350 kg	1,112 kg
FXC302008	650 L	1,412×1,319×1,509 mm	459 kg	1,572 kg
FXC302009	1,000 L	1,511×1,435×1,710 mm	595 kg	2,105 kg
FXC302010	1,500 L	1,900×1,135×2,530mm	794 kg	2,969 kg
FXC302011	2,000 L	1,900×1,135×3,050 mm	936 kg	3,724 kg
FXC302012	2,500 L	1,900×1,135×3,570 mm	1,079 kg	4,492 kg
FXC302013	3,000 L	1,900×1,135×4090 mm	1,221 kg	5,236 kg

Hardware

Pro Mixer Drive Unit

Description	Unit	Value
Dimensions (width × length × height)	mm	439 × 1,242 × 1,006
Weight	kg	100
Materials		Device surfaces: 316L 1.2 Ra Display: Foil coated with polyester foil Castors: Polyamide
Mobility		Mounted on stainless cart with four clean room wheels and push handle
Initial set-up time		Not applicable
Speed of the impeller	rpm	20 - 750
Maximum speed allowed (rpm)	rpm	50 - 3,000 L: 750
Working Temperature	°C	+2 - +30
Relative humidity, maximum (at temperatures of up to 31°C)	%	80
Protection class according to IEC 60529: HMI handle		IP 23
Protection class according to IEC 60529: electrical cabinet		IP 54
Voltage	VAC	100 - 240 ±10 %
Frequency	Hz	50 - 60
Performance (Current consumption), maximum	W	1200
Length of the power supply cable	m	10
Acoustic pressure level, max.	dB (A)	60
Operating Modes		Local operation (Manual, Recipe) Remote Operation
Remote Operation	V	0 - 10 Input signals from remote control
	mA	4 - 20 Output signals of the device in remote operation
Remote Operation (Available functions)		<ul style="list-style-type: none"> ▪ Motor - start, stop ▪ Speed - adjustment, indication ▪ Alarm - indication ▪ Mode of control (remote local) - indication
Type of connection cable for remote operation		8-position, shielded, Plug straight M12, coding: A, on Socket straight M12, coding: A
Recipe storage		25 Number of recipes, max. 10 Number of phases in the recipe, max.
Compliance		CE UL



Item	Quantity	Part Number
Flexsafe® Pro Mixer Drive Unit*	1	FMD300001
Power supply cable - EU	1	FMA303410
Power supply cable - US	1	FMA303411
Power supply cable - Switzerland	1	FMA303412
Power supply cable - Australia	1	FMA303413
Power supply cable - Great Britain	1	FMA303415
Connection cable for remote operation, length 5 m	1	FMA303416

* the drive unit box includes one power supply cable (EU) and one power supply cable (US)

Hardware

Accessories

Powder Transfer System

Tubing Holder

Filter Holder

pH Reader Holder and pH Bag Holder



Powder Bag Holders

Description	Powder Bag Holder 50 L to 200 L	Powder Bag Holder 400 L to 1,000 L	Powder Bag Holder 1,500 L to 3,000 L
Part Number	FXA304216 for EU FXA304246 for North America	FXA304217 for EU FXA304247 for North America	FXA304218 for EU FXA304248 for North America
Construction material	Stainless Steel 304 and Nylon		
Surface finish	Bead Blasted		
Dimensions	660 × 1,360 mm	960 × 1,360 mm	860 × 1,360 mm
Weight	14 kg	16 kg	14 kg
Height above Palletank	1349 mm	1349 mm	1349 mm
Filling weight, maximum	30 kg	30 kg	30 kg
Ambient Conditions	+2°C – +30°C	+2°C – +30°C	+2°C – +30°C

Hardware

Accessories

Powder Transfer System

Tubing Holder

Filter Holder

pH Reader Holder and pH Bag Holder



Powder Transfer Bags

Description	Technical Specifications
Bag Chamber	Multiple layer film construction, (mLLDPE MDPE-LDPE mLLDPE)
Fittings	4-inch triclamp
Accessory	Pinch clamp
Volumes	15 L and 30 L
Number of Port	1 port
Irradiation	25-45 kGy

Triclamp Reducer

Description	Technical Specifications
Triclamp Reducer	8-inch to 4-inch triclamp reducer with a 4-inch triclamp plug, 4-inch triclamp gasket and 4-inch triclamp union
Material of Construction	Reducer: polyethylene Plug: polyethylene Gasket: platinum cured silicone 4-inch triclamp union: glass reinforced polyamide
Sterility	Non sterile

Cap | Gasket | Union

Description	Technical Specifications
Cap Gasket Union	4-inch triclamp plug, 4-inch triclamp gasket, 4-inch triclamp union
Material of Construction	Plug: polyethylene Gasket: platinum cured silicone 4-inch triclamp union: glass reinforced polyamide
Sterility	Non sterile

Part Number	Description	Bag Port 1	Qty. Box
FMA300221	STD Powder Bag 15 L (PWD Port) with pinch clamp	4-inch triclamp	5
FMA300222	STD Powder Bag 30 L (PWD Port)with pinch clamp	4-inch triclamp	5
FMA114007	8-inch to 4-inch triclamp reducer	n/a	1
FMA114179	Component Plug Gasket Union for TC4"	n/a	5

Hardware

Accessories

Powder Transfer System

Tubing Holder

Filter Holder

pH Reader Holder and pH Bag Holder



Tubing Holder

Description	Part Number	Type	Outer Tube Diameter	Material	Surface Finish	Dimensions	Weight
Tubing Holder Single 5/8"	FXC301562	Single	5/8"	Stainless Steel 304 and TPE	Bead Blasted	139 × 68 mm	423 g
Tubing Holder Twin 5/8"	FXC301563	Twin	5/8"			150 × 113 mm	465 g
Tubing Holder Triple 5/8"	FXC301564	Triple	5/8"			150 × 158 mm	506 g
Tubing Holder Quattro 5/8"	FXC301565	Quattro	5/8"			150 × 205 mm	546 g
Tubing Holder Single 3/4"	FXC301566	Single	3/4"	Stainless Steel 304 and TPE	Bead Blasted	139 × 77 mm	427 g
Tubing Holder Twin 3/4"	FXC301567	Twin	3/4"			150 × 132 mm	474 g
Tubing Holder Triple 3/4"	FXC301568	Triple	3/4"			150 × 188 mm	518 g
Tubing Holder Quattro 3/4"	FXC301569	Quattro	3/4"			150 × 243 mm	559 g
Tubing Holder Single 1"	FXC301570	Single	1"	Stainless Steel 304 and TPE	Bead Blasted	139 × 86 mm	434 g
Tubing Holder Twin 1"	FXC301571	Twin	1"			160 × 151 mm	510 g
Tubing Holder Triple 1"	FXC301572	Triple	1"			160 × 216 mm	571 g
Tubing Holder Quattro 1"	FXC301573	Quattro	1"			160 × 281 mm	626 g
Tubing Holder Single 1 1/8"	FXC301574	Single	1 1/8"	Stainless Steel 304 and TPE	Bead Blasted	146 × 86 mm	445 g
Tubing Holder Twin 1 1/8"	FXC301575	Twin	1 1/8"			160 × 151 mm	510 g
Tubing Holder Triple 1 1/8"	FXC301576	Triple	1 1/8"			160 × 216 mm	570 g
Tubing Holder Quattro 1 1/8"	FXC301577	Quattro	1 1/8"			160 × 281 mm	627 g

Hardware

Accessories

Powder Transfer System

Tubing Holder

Filter Holder

pH Reader Holder and pH Bag Holder



Tubing Holder

Description	Part Number	Type	Outer Tube Diameter	Material	Surface Finish	Dimensions	Weight
Tubing Holder Single 1 3/8"	FXC301578	Single	1 3/8"	Stainless Steel 304 and TPE	Bead Blasted	156 × 89 mm	454 g
Tubing Holder Twin 1 3/8"	FXC301579	Twin	1 3/8"			171 × 157 mm	527 g
Tubing Holder Triple 1 3/8"	FXC301580	Triple	1 3/8"			171 × 225 mm	595 g
Tubing Holder Quattro 1 3/8"	FXC301581	Quattro	1 3/8"			171 × 293 mm	657 g

Hardware

Accessories

Powder Transfer System

Tubing Holder

Filter Holder

pH Reader Holder and pH Bag Holder



Filter Holder

Description	Part number	Type	Filter diameter	Material	Surface finish	Dimensions	Weight
Filter Holder Short 55 mm	FXC301582	Short	55 mm	Stainless Steel 304 and TPE	Bead Blasted	100 × 55 mm	596 g
Filter Holder Long 55 mm	FXC301583	Long	55 mm			500 × 55 mm	1,519 g
Filter Holder Short 75 mm	FXC301584	Short	75 mm	Stainless Steel 304 and TPE	Bead Blasted	100 × 75 mm	672 g
Filter Holder Long 75 mm	FXC301585	Long	75 mm			500 × 75 mm	1,596 g
Filter Holder Short 100 mm	FXC301586	Short	100 mm	Stainless Steel 304 and TPE	Bead Blasted	100 × 100 mm	735 g
Filter Holder Long 100 mm	FXC301587	Long	100 mm			500 × 100 mm	1,658 g

Hardware

Accessories

Powder Transfer System

Tubing Holder

Filter Holder

pH Reader Holder and pH Bag Holder



pH Reader Holder and pH Bag Holder

Description	Part number	Material	Surface finish	Dimensions	Weight
Palletank for Mixing pH Reader Holder	FXA304214	Stainless Steel 304 and elastomer	Bead Blasted	245 × 170 × 181 mm	1,499 g
Palletank for Mixing pH Bag Holder	FXA304215			160 × 181 × 212 mm	1,519 g

Design, Application Development and Validation Services

Design Configuration Options

Should our Pre-designed Solutions need to be adjusted to more specific requirements, they can serve as a base for adjusting your specific design using our Corporate Configurator and configure to Order (CTO) solutions.

Our Engineered to order (ETO) solutions allows the selection of a larger variety of solutions with added features, lines, manifolds, filters, connectors and sampling systems.

Please contact our sales representatives and application specialist to support you with the selection and design of a solution ideally suited for your specific process and application.

Application Support

Our expert FMT Application Specialists provide global support for:

- Single-use process URS definitions and application development
- Process design with standard and custom solutions
- Filter selection and sizing optimization study
- SOP development, process validation and operator training
- Technology transfer and process optimization

Validation Service

Our global validation services network offers:

- Installation start up, FAT, IQ & OQ, calibration and maintenance
- Consultancy service and process specific validation studies including
- Extractables | leachables,
- Chemical compatibility
- Bacterial challenge test
- Particle shedding



Germany

Sartorius Stedim Biotech GmbH
August-Spindler-Strasse 11
37079 Goettingen
Phone +49 551 308 0

USA

Sartorius Stedim North America Inc.
565 Johnson Avenue
Bohemia, NY 11716
Toll-Free +1 800 368 7178

 For further contacts, visit
[sartorius.com](https://www.sartorius.com)